



2031 Adams Road
Sedalia, Missouri 65301

tel 660.829.5100
fax 660.829.1160

Sedalia, 10 de Octubre de 2008

Ana María González
Corpoelec
Caracas, República Bolivariana de Venezuela

Re: Proyecto Emergencia eléctrica

Estimada Dr. González:

De acuerdo a su requerimiento de equipos de generación para la República Bolivariana de Venezuela, nuestra empresa se complace en presentarle las siguientes oferta con maquinas que se encuentran disponibles en un tiempo relativamente corto;

Nuestra empresa tiene acceso a las siguientes maquinas con el siguiente tiempo de entrega:

2 x Pratt & Whitney FT-4 con una potencia de 54MW cada una.

Precio: US \$ 19, 000,000.00 Por Unidad

Tiempo de Entrega: 90 Días

2 x Rolls Royce RB211 con una potencia de 25MW Por Unidad.

Precio: US \$ 14, 000,000.00 Por Unidad

Tiempo de Entrega: 90 Días

2 x GE LM2500 con una potencia de 22MW cada una.

Precio: US \$ 12, 500,000.00 Por Unidad

Tiempo de Entrega: 116 Días

3 x GE Frame 7F (maquinas nuevas lista para ser enviadas a Venezuela con una potencia de 171MW cada una.

Precio: US \$ 54, 700,000.00 Por Unidad

Tiempo de Entrega: 90 Días

1 x GE LM6000 de 44MW. Esta máquina se encuentra en operación hasta Diciembre de este año y podemos reacondicionarla y alistarla para enviarla a Venezuela 90 días después.

Precio: US \$ 23, 500,000.00

Tiempo de Entrega: 120 Días

4 x Rolls Royce Trent, 60 MW cada máquina. Este generador de nueva tecnología está en la línea de producción de Rolls Royce.

Precio: US \$ 27, 200,000.00 Cada Una

Tiempo de Entrega: 267 Días

Todas estas maquinas son: FOB Puerto de Embarque

Todas estas maquinas están sujetas a venta previa, Ningún impuesto fue considerado

Desde aquí estamos a su mejor disposición para poder ayudar técnicamente a su empresa y poder colaborar con la necesidad de energía requerida por Venezuela.

Anexo a la presente encontraras información referente a todos los paquetes de generación que Proenergy tiene disponible.

Proenergy junto con nuestro socio Pacific Rim somos una de las pocas empresas que pueden ofrecer mantenimiento y operación, equipos (nuevos y/o usados), reparaciones, partes y piezas, la erección, la construcción, arranque y garantía de todos estos equipos. Esta garantía es similar a la ofrecida por los fabricantes originales de estas.

Estimada Ana en estos proyectos de emergencia sabemos que hay muchas piezas que armar y el tiempo es indispensable para el buen funcionamiento de ellos, por lo que queremos ofrecerles nuestro total soporte a Corpoelec. Nuestro equipo está listo para partir a Venezuela y empezar con la labor de ayudar a construir un mejor país con Electricidad.

Recibe un abrazo y quedando siempre a tus ordenes



Joaquin S. Mavares
Director de Ventas Internacionales
ProEnergy Services.

CC: Jeff Canon
John Stevens



2031 Adams Road
Sedalia, Missouri 65301

tel 660.829.5100
fax 660.829.1160

Houston 22 de Mayo Del 2008

**Khaled Khalil
Pacific Rim
Edificio Creditcard
Piso 8
Caracas, DF Venezuela**

Ref: Proyecto de Generación Distribuida

Estimado Khaled:

Nuestra empresa Proenergy Services está bien activa en el mercado de generación eléctrica a nivel mundial, esto nos ha permitido ubicar en el mercado secundario maquinas con entrega relativamente rápida.

Estas maquinas se tendrían que reacondicionar para poder ofrecer las garantía necesaria para tus proyectos.

En los momentos Proenergy Services puede ofrecer los siguientes equipos:

Mercado Secundario (todos los equipos están sujetos a venta previa):

- **Seis (6) Pratt & Whitney FT-4 de 50MW (ISO) cada una.
Precio estimado: \$ 12, 000,000.00 cada turbina. FOB puerto de embarque.**
- **Dos (2) Rolls Royce RB211 de 27.5MW (ISO) cada una.
Precio estimado: \$ 8, 500,000.00 cada turbina. FOB puerto de embarque.**
- **Una (1) GE LM2500 de 22MW (ISO)
Precio Estimado: \$7, 400,000.00. FOB puerto de embarque.**
- **Ocho (8) GE Frame 7EA de 85MW (ISO) cada una.
Precio estimado: \$25, 000,000.00 cada una. FOB puerto de embarque.**
- **Cuarenta (40) 2000QT Catepillar de 1.75MW (ISO) cada una.
Precio estimado de cada unidad en su contenedor es
US \$550,000 FOB puerto de embarque.**

Unidades Nuevas

Como hemos hablado anteriormente la situación de los fabricantes de turbinas en los momentos es bastante comprometida ya que el mercado mundial está necesitando energía. Hemos contactado a los fabricantes de turbinas y esta la información que nos dieron.

Rolls Royce

Equipo producido Trent 60, esta máquina produce 64MW en condiciones ISO y tiene un tiempo de entrega para Marzo del 2010 para las dos primeras maquinas y pueden entregar una cada siguiente mes a un precio estimado hoy de US \$ 20,000,000.

Pratt and Whitney

El equipo producido es la maquina FT-8-3 Swift Pac 60 esta máquina produce 60MW (ISO) y tiene un tiempo de entrega de 12 Meses para las dos primeras y un mes después cada dos maquinas. Su precio es de US \$ 22, 000,000.00 cada máquina FOB puerto de embarque.

General Electric

Esta empresa ofrece la turbina LM6000 de 56MW (ISO) y su tiempo de entrega esta por los doce meses y a un precio de US \$ 17, 000,000 FOB Houston.

Todas estas empresas lo que están haciendo ahora es vendiendo el cupo en la línea de producción, esto quiere decir que hay que depositar un porcentaje en la compra y hacer pagos progresivos. El tiempo de entrega lo conseguí gracias a nuestros contactos, como sabes trabajé para todas ellas por un tiempo y aun me quedan amigos en ellas.

Ellos me han dicho que el tiempo se podría mejorar pero hay que poner la orden inmediatamente por si ocurre una cancelación y nos podrían ayudar a tomar ese puesto en la línea de producción.

Como sabes todo lo relacionado al EPC, mantenimiento, arranque, comisionamiento y los equipos auxiliares Proenergy es la empresa con más experiencia en este tipo de equipos que en su mayoría son aereoderivados. Nuestra experiencia en la instalación pasa de los 80 turbogeneradores instalados en el mundo.

Te estoy anexando nuestra lista de experiencia, como también alguna información típica de algunos de los equipos que te mencione anteriormente. Nota estos son generales y no representan exactamente los que te estamos ofreciendo.

De estar interesados podríamos presentarte una propuesta completa incluyendo el proyecto llave en mano completo por los equipos que ustedes elijan así también como el mantenimiento y la operación si fuese necesario.

Quedando siempre a tus ordenes y esperando poder darte una respuesta a tus necesidades de generación.

Atentamente

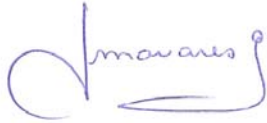
A handwritten signature in blue ink that reads "Joaquin S. Mavares". The signature is fluid and cursive, with the first name being the most prominent.

Joaquin S. Mavares
Director de Ventas Internacionales

CC: Jeff Canon
John Stevens
Al Rivera

Referencias



RB211 GAS TURBINE PACKAGE

The Coberra 6462 GT Units utilizes a Rolls Royce RB211 GG and an RT62 PT. The PT is coupled to an AC Gen via reduction gearbox. The gen set itself is comprised of 5 main packages, each being of modular construction for ease of transportation, handling at site, and assembly.

The Rolls Royce RB211-24C Mark 1750 GG two spool high pressure ratio engine with a seven stage intermediate pressure compressor, and a six stage high pressure compressor which drives two independent single stage turbines couples to the compressors through coaxial shafts. The two rotors of the GG are mechanically independent and run at their own optimum speeds.

Gas Turbine (GG)

Manufacturer: Rolls Royce
Model: RB211-24C
N1 Speed: 6555 RPM
Fuel: Dual Fuel currently operating on natural gas

Power Turbine (PT)

Manufacturer: Cooper Bessemer
Model: RT62 PT two stage impulse reaction
Rated HP: 27,749 (ISO)
Rated Speed: 4800
Maximum Continuous Speed: 5050 RPM
Serial Numbers: 602RT and 654RT
Overspeed Trip: 5450
Turbine Inlet Pressure: 43.2 psia @ 40F ambient
Turbine Inlet Temp: 1320F @ 40F ambient
Turbine Exhaust Temp: 861F @40F ambient
Lubrication: Mineral Oil 150 SSU

Gear Reducer

Manufacturer: Lufkin
Model Number: F33070
Rating: 35,960 Hp
Service Factor: 1.35
Input Speed: 4800 Rpm
Output Speed: 1800 Rpm
Gear Ratio: 2.660:1

AC Generator

Manufacturer: Brush Electrical Machines, LTD
Model: BSGMD 131-290-4
Type: 4 Pole
RPM: 1800
Volts: 12500
Amps: 1454
Phase: 3
HZ: 60
Power Factor: 0.85

Air Filter System

GT Intake: American Air Filter
AC Gen Air Vent Filter: American Air Filter

Main and Auxiliary Lube Oil Pumps and AC Motors

Pump Manufacturer: Transamerica DeLaval
Pump Rating: 310 GPM@ 1750 RPM and 77 PSI
Motor Manufacturer: Westinghouse
Motor Rating: 30 HP, 1750 RPM, 3 Phase, 60 HZ, 460 V

Emergency Lube Oil Pump and DC Motor

Pump Manufacturer: Transamerica DeLaval
Pump Rating: 257 GPM @1750 RPM and 77 PSI
Motor Manufacturer: Reliance
Motor Rating: 20HP, 1800 RPM, 125VDC

Georgia
1395 S. Marietta Pkwy SE,
Suite 218
Marietta, Georgia 30067

Missouri
2031 Adams Road
Sedalia, MO 65301

Texas
1616 FM 1960 West
Suite 750
Houston, Texas 77090

ProEnergy Services de Venezuela C.A.
Urbanización Los Caobos, Paseo Colón,
Torre Polar Oeste, Piso 4, Oficina 4-C
Plaza Venezuela - Caracas
Venezuela

 **ProEnergy**
SERVICES
"Experience Our Energy"



RB211 GAS TURBINE PACKAGE

Water Forwarding Pumps

Pump Manufacturer: Transamerica DeLaval
Pump Rating: 5GPM @3500 RPM and 400 PSI
Motor Manufacturer: Westinghouse
Motor Rating: 3 HP, 3500 RPM, 3 Phase 60 HZ , 460V

Lube Oil Cooler

Cooler Manufacturer: Air-X-Changer
Cooler Rating: RT Sec 1,850,000 BTU/HR @234 GPM
Motors Manufacturer: Westinghouse
Motors Rating: 10HP, 1800 RPM, 3 Phase, 60 HZ, 460 V
Type: Fin Fan Radiator

Lube Oil Filter

Manufacturer: Hilco
Model: 52718-0150-2006
Type: Duplex

Capacities in Approximate U.S. Gallons

PT Lube Oil Reservoir: 2500
GG Lube Oil Reservoir: 88
GG Lube Oil Accumulator: 1.5
GG Cleaner Tank: 45

Coupling-Power Turbine to Gear

Manufacturer: Zurn Industries
Model: Ameriflex Series HPS
Type: Flex

Coupling-Gear to AC Gen

Manufacturer: Zurn Industries
Model: Ameriflex, Series HPP
Type: Flex

Fuel Gas Preheater

Manufacturer: Bas-Tex Corporation
Model: 06060
Shell Side: 340 PSIG
Tube Side: 960

Air Conditioning Equipment (Not included)

2 Trane Horizontal Flow P/N TORR-IM-2D

Building Info

Building with 25 TON Bridge Gaffey Crane
Battery room located inside Generator Building
60 ft. x 125 ft. x 38 ft. at the eave and 45 ft. at the peak

HVAC Equipment

Manufacturer: Frees, Inc.

Centrifugal Fans

2 Buffalo Forge Ventilating Fans

Demin Water Storage Tank

Manufacturer: Southwest Tank & Treater
Capacity: 15,000 gallons

HCL Tank

Manufacturer: Southwest Tank & Treater

Caustic Storage Tank

Manufacturer: Southwest Tank & Treater
Capacity: 3,000 gallons

High Pressure Fuel Gas Scrubber

Manufacturer: Southwest Computer Inc.
Description: 640 PSIG @ 300F 36" ID X 10FT

Turbine Exhaust Duct

Manufacturer: Fish Engineering & Construction

Demineralization System Package

Manufacturer: H-O-H Systems INC.

480 Volt MCC

Manufacturer: Westinghouse Five Star MCC

Battery Chargers

Manufacturer: Sab Nife Corporation

Waste Heat Recovery (Not included)

58.52MM BTU/HR (ea)
470 PSIG @ 650F
Burner design case (663,120 LB/HR)
Turbine exhaust gas (600,840 LB/HR)

Georgia
1395 S. Marietta Pkwy SE,
Suite 218
Marietta, Georgia 30067

Missouri
2031 Adams Road
Sedalia, MO 65301

Texas
1616 FM 1960 West
Suite 750
Houston, Texas 77090

ProEnergy Services de Venezuela C.A.
Urbanización Los Caobos, Paseo Colón,
Torre Polar Oeste, Piso 4, Oficina 4-C
Plaza Venezuela - Caracas
Venezuela



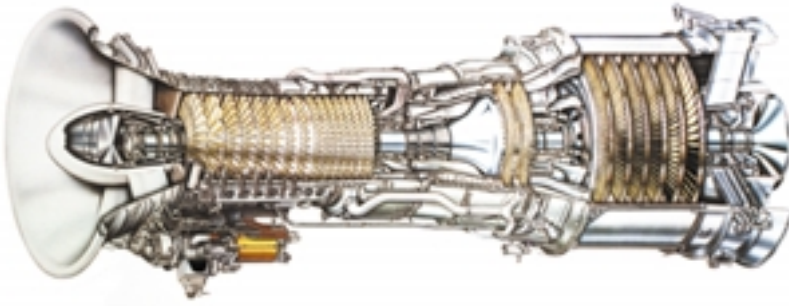

LM2500 Gas Turbine

Technology

Derived from the CF6 family of aircraft engines used on wide body jet liners, the LM2500 family is a hot-end drive, two-shaft gas generator with free power turbine. Thermal efficiencies are from 34% to 40%.

- Baseload Power Capabilities of 18 - 32 MW ISO
- Unsurpassed Reliability – Exceeding 99%
- Three Models with a High Degree of Parts Commonality

Experience

Maintaining a high degree of commonality with its flight-tested forerunners, the LM2500 family continues to build its reputation as the most reliable industrial gas turbine generator in its class.

- 40 Million Operating Hours
- More than 2,000 units
- End-users: Mechanical Drive and Power Generation for Industrial Plants, Pipelines, Platforms and Marine Ships
- Configurations: Simple-cycle, Cogeneration and Combined-Cycle

Innovation

GE Aero Energy offers three models in the LM2500 family of products: LM2500+

- Providing More Than 30 MW ISO
- Power Generation, Marine and Mechanical Drive Applications
- Available in a 6-stage or 2-stage Power Turbine Configuration

LM2500

- Produces in Excess of 22 MW ISO
- Operates at 3000 or 3600 rpm Without a Gearbox
- Optional Steam Injection (STIG) for Power Enhancement

LM2000

- Capable of 18 MW ISO
- Extended Maintenance Intervals

ISO performance based on natural gas with water injection to 25 ppmvd NOx.

	LM2000	LM2500	LM2500+
Power Output (kWe)	18,000	22,000	30,500
Heat Rate LHV (Btu/kWe-Hr)	9,900	9,465	8,850
Exhaust Flow (lbs/sec)	134	149	191
Exhaust Temperature (°F)	927	990	960
Emissions (ppmvd)	NOx/CO	NOx/CO	NOx/CO
Gas-DLE	25/25	25/25	25/25
Gas or Liquid-Water	25/75, 42/68	25/50, 42/30	25/60, 42/60
Gas-Steam	25/74	25/30	25/138
Power Turbine Speed (rpm)	3,600	3,600	3,600
No. of Compressor Stages	16	16	17
No. of Turbine Stages	6	6	6 or 2

Service

GE Aero Energy is the world's largest aeroderivative service provider, with a global network of field service offices and fully equipped depots. A wide range of products and services are offered for the LM2500+, LM2500, and LM2000 Industrial, Cogeneration, and Oil & Gas operators, including:

- Level IV depot repair and overhaul capability in Houston, Texas; Rheden, The Netherlands, and Agotnes, Norway
- Conversions, Modifications and Upgrades (CM&U) designed to enhance the efficiency, power output and reliability of the LM2500, such as Exhaust Flow Enhancer, Wet/Dry Low Emissions (DLE) Upgrades; Inlet Conditioning, Fuel Conversions, Remote Monitoring and Diagnostics, among many others
- Spare or Lease Engine Options
- Engine Exchange Programs
- Rotable Hot Section and Module Exchange Programs
- Wide Variety of Contractual or Long-Term Service Agreements

This comprehensive product offering, combined with GE Aero Energy's commitment to reduced depot and outage turn times, results in substantial life cycle cost savings for the plant owner/operator.

LM2500 60Hz Output and Heat Rate

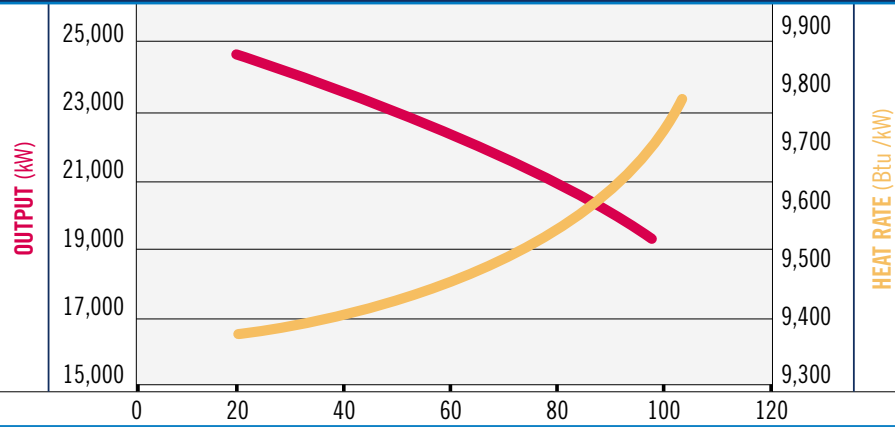

0 ft, 60% RH, 4/6 in H₂O inlet/exhaust loss on natural gas with water injection to 25ppmvd NOx water inj.

AMBIENT (°F)

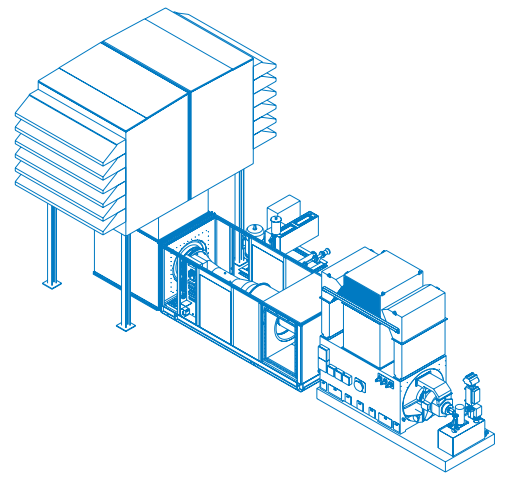

LENGTH 68'6" x WIDTH 14'9" x HEIGHT 29'5"

STANDARD 60HZ LM2500 GENERATOR PACKAGE

Gas Turbine

- 16 Stage Axial Compressor
 - > 1st 6 Stages are VIGV
 - > Horizontal Split Casing
 - > 20:1 Compression Ratio
 - > 103 lb/s Nominal Inlet Mass Flow
- Annular Combustor
 - > 30 Nozzles Gas Fuel, Water Injection for NOx Control
- 6 Stage Power Turbine

Generator

- Continuous Duty 13.8kV, 0.85 PF
- 2 pole, 3 Phase Brushless Exciter
- WP11 Weather Protected
- Voltage Regulator/Neutral Side Protection CT's
- NEMA Class F Insulation & B Temperature Rise

Package

- 24V and 125V DC Batteries
- 90dBA Near Field Design
- Barrier Inlet Air Filters
- Electro-hydraulic Start System
- Class I Div 2 Group D Class Electrical System
- Digital Control System with a Human Machine Interface (HMI)
- Turbine and Generator Lube Oil System with Simplex Shell and Tube Coolers
- Turbine Factory Tested
- On/Off-line Water Wash
- 1 Year Parts/Service Warranty
- Package Familiarization Training
- Electronically Transmitted Drawings
- Startup Technical Assistance

OPTIONAL EQUIPMENT AND SERVICES

- Generator Options
 - > TEWAC
 - > Voltages: 12.47kV
 - > Enclosure
 - > Fault Protection
- Fuel System
 - > Liquid
 - Water Injection or DLE
 - > Dual
 - Water Injection or DLE
 - > Gas
 - Water or Steam Injection or DLE
 - > Filters
- Control System
 - > 10 minute start
 - > Black start
 - > Continuous Emission Monitoring
 - > Remote Display
 - > Control House
 - > Motor Control center
- Lube Oil System
 - > Air to Oil Coolers
 - > First Fill Lubricants
- Winterization
- Remote Monitoring and Diagnostics
- Pulse Air Filter
- Inlet Conditioning
 - > Evaporative Cooling
 - > Chilling
 - > Heating



XQ2000 SOUND ATTENUATED POWER MODULE 60HZ

FEATURES:

Emissions

EPA and CARB Emissions Certified for non-road mobile applications.

CAT® Diesel Generator Sets

Factory designed, certified prototype tested with torsional analysis. Production tested and delivered to you in a package that is ready to be connected to your fuel and power lines. Electric Power Design Pro computer sizing available. Supported 100% by your Caterpillar dealer with warranty on parts and labor. Extended warranty available in some areas. The generator set was designed and manufactured in an ISO 9001 compliant facility. Generator set and components meet or exceed the following specifications: AS1359, AS2789, ABGSM TM3, BS4999, DIN6271, DIN6280, EGSA101P, JEM1359, IEC 34/1, ISO3046/1, ISO8528, NEMA MG1-22.

CATERPILLAR® SR4B Generator

Single bearing, wye connected, static regulated, brushless permanent magnet excited generator designed to match the performance and output characteristics of the Caterpillar diesel engine that drives it.

Reliable, Fuel Efficient Diesel

The compact, four-stroke-cycle diesel engine combines durability with minimum weight while providing dependability and economy. The fuel system operates on a variety of fuels.

CATERPILLAR® Cooling System

Sized compatible to rating with energy efficient fan and core.

CATERPILLAR® Switchgear

Single unit or optional paralleling components. Circuit breakers, bus bars, and connection panel ready to connect.

Exclusive CATERPILLAR® Voltage Regulator

Three-phase sensing and adjustable Volts-per-Hertz regulation give precise control, excellent block loading, and constant voltage in the normal operating range.

Sound Attenuated ISO Container

For ease of transportation and protection. Meets 70 dBA at 50 ft or below per SAE J1074 measurement procedure.

Georgia
1395 S. Marietta Pkwy SE,
Suite 218
Marietta, Georgia 30067

Missouri
2031 Adams Road
Sedalia, MO 65301

Texas
1616 FM 1960 West
Suite 750
Houston, Texas 77090

ProEnergy Services de Venezuela C.A.
Urbanización Los Caobos, Paseo Colón,
Torre Polar Oeste, Piso 4, Oficina 4-C
Plaza Venezuela - Caracas
Venezuela





XQ2000 SOUND ATTENUATED POWER MODULE 60HZ

FACTORY INSTALLED STANDARD & OPTIONAL EQUIPMENT:

System	Standard	Optional
Engine	Air cleaner, with service indicator Batteries Filters; fuel, LH with service indicators; lubricating oil Insulated muffler Jacket water heater Pump, fuel priming — LH Radiator Service meter Standard eight-gauge instrument panel Sump pump Governor Electronic ADEM II	
Generator	SR4B brushless, 480 volt, PM excited three-phase with digital voltage regulator, space heater	
Containerized Module	Air intake louvers Bus bar access door Fuel tank — 4730 L (1250 Gal) UL listed Fuel/water separator 110 VAC/24 VDC lighting Sound attenuated (75 dBA @ 50 ft) ISO hi cube container Lockable doors Stainless steel hardware and hinges Vertical radiator and exhaust discharge plenum	
Cooling	Standard cooling provides 110° ambient at prime rating	
Switchgear	Floorstanding switchgear with EMCP II components Automatic start/stop with cooldown timer Battery charger, heavy duty 20A Protection: 32, 59 Circuit breaker, electrically operated Connection terminals, 3-phase and neutral Automatic paralleling Auxiliary power connections for jacket water heater, battery charger, space heaters	Meters: power factor, KW, PF, W/WHM, synchroscope, KVAR Protection: 27, 40, 810, 81U CIM, CCM, remote annunciation Plug and peak shave utility conversion panel

SPECIFICATIONS:

CAT® SR4B Generator

Type Static regulated brushless PM excited
Construction Single bearing, close coupled
Three-phase Wye connected — 6 lead
Insulation Class H — 2 extra dips and bakes on random wound units
Enclosure Drip proof
Alignment Pilot shaft
Overspeed capability 130%
Voltage regulator 3-phase sensing with Volts-per-Hertz
Voltage regulation Less than ±0.5%

Voltage gain Adjustable to compensate for engine speed droop and line loss
Wave form Less than 5% deviation
TIF Less than 50
THD Less than 3%

CAT® 3516B Engine

V-16, 4-stroke-cycle diesel
Bore — mm (in) 170 (6.7)
Stroke — mm (in) 190 (7.5)
Displacement — L (cu in) 69.0 (4210)
Aspiration Turbocharged-Aftercooled

Georgia
1395 S. Marietta Pkwy SE,
Suite 218
Marietta, Georgia 30067

Missouri
2031 Adams Road
Sedalia, MO 65301

Texas
1616 FM 1960 West
Suite 750
Houston, Texas 77090

ProEnergy Services de Venezuela C.A.
Urbanización Los Caobos, Paseo Colón,
Torre Polar Oeste, Piso 4, Oficina 4-C
Plaza Venezuela - Caracas
Venezuela



XQ2000 SOUND ATTENUATED POWER MODULE 60HZ

TECHNICAL DATA:

Power Rating 60 Hz	ekW	Standby 2000	Prime 1825
Engine and Container Information Engine Model Container size Container dimensions	m (ft)	3516B 12 (40) see below	
Fuel Capacity Hours of Operation at 60% Load Factor 4732 L (1250 Gal) Standard 12 m (40 ft)	hours	8	9
Approximate Weight (Dry) — Container with Generator Set and Switchgear Including Container With Undercarriage	kg (lb) kg (lb)	32 660 (72,000) 40 370 (89,000)	

Container Dimensions

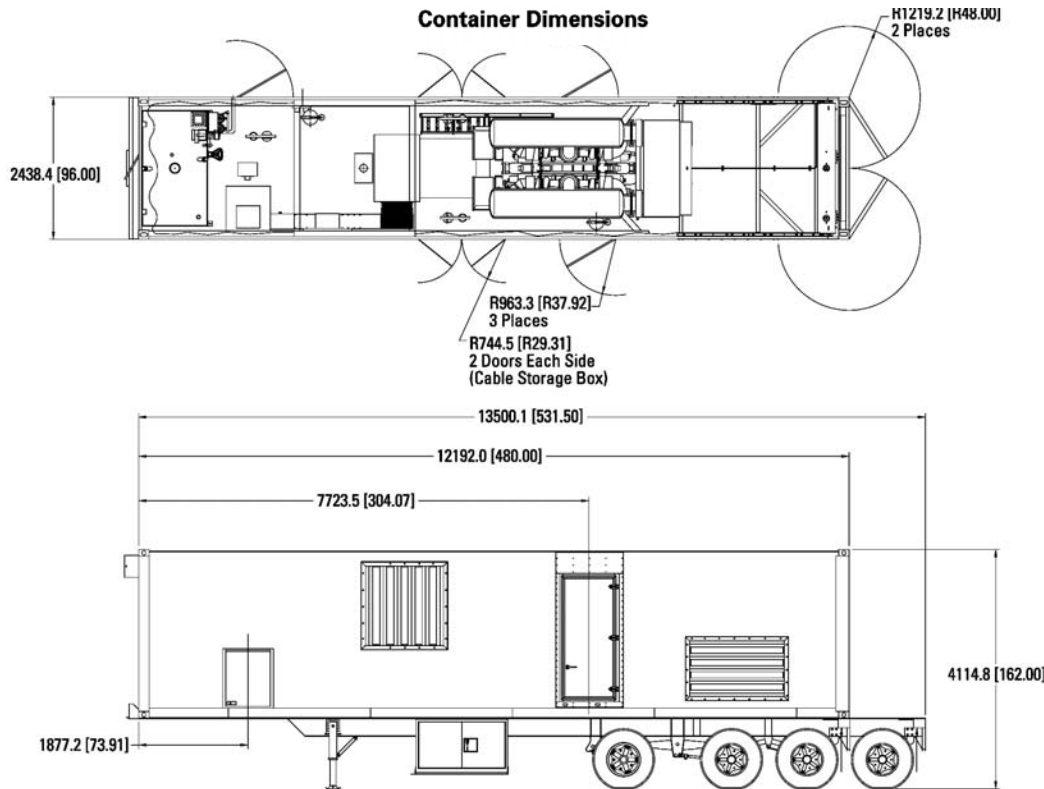

The power module must have support under the center when set on the ground.

Dimensions		
Length	13500.1 mm	531.50 in
Width	2438.4 mm	96.00 in
Height	4114.8 mm	162.00 in

Georgia
1395 S. Marietta Pkwy SE,
Suite 218
Marietta, Georgia 30067

Missouri
2031 Adams Road
Sedalia, MO 65301

Texas
1616 FM 1960 West
Suite 750
Houston, Texas 77090

ProEnergy Services de Venezuela C.A.
Urbanización Los Caobos, Paseo Colón,
Torre Polar Oeste, Piso 4, Oficina 4-C
Plaza Venezuela - Caracas
Venezuela





XQ2000 SOUND ATTENUATED POWER MODULE 60HZ

STANDARD CONTROLS:

12 m (40 ft) Containers 480V/60 Hz

Floorstanding switchgear includes the following functions and features:

Electronic Modular Control Panel (EMCP II) Components Generator Set Control (GSC)

Monitoring

Sequentially rotating, backlit LCD display of engine hours, engine rpm, DC battery voltage, oil pressure, and water temperature. Includes pushbutton to hold display on any single parameter.

Protection

Shutdowns:

Overspeed, overcrank, high water temperature, low oil pressure, and emergency stop. With LED indicator for each condition.

Alarms:

Low coolant level

AC Metering

Three-phase volts (L-L), amperes and frequency with phase select pushbutton, on backlit LCD. Metering accuracy is 0.5%.

Control

Automatic starting with field adjustable cycle crank, failure to start (overcrank), and cooldown timer.

Programming and Diagnostics

Includes field programmable set-points for engine control and monitoring variables and self diagnosis of EMCP II system component and wiring failures.

Alarm Module

Flashing LED warnings for: low coolant temperature, high coolant temperature (pre-alarm), low oil pressure (pre-alarm), engine control switch not in automatic, and low DC voltage. Includes alarm horn and acknowledge pushbutton.

Engine Control Switch

Snap action rotary switch, four-position — off/reset, automatic, manual, stop/cooldown. Off/reset for engine shutdown and resetting faults, automatic for remote starting by customer contact closure, manual for local starting and manual paralleling, stop/cooldown for manual operation cooldown.

Alarm Acknowledge/Lamp Test Switch

Three-position, spring return to center switch for alarm acknowledge and lamp test of all discrete indicating lamps. Lamp test shall also sound the alarm horn.

Annunciation Circuits

Upon receipt of an alarm or shutdown condition, the horn shall sound and an LED shall flash. Upon acknowledgement from alarm acknowledge/lamp test switch, the horn shall be silenced and the lamp steadied. LED shall be extinguished when ECS is placed in the off/reset position if the alarm condition has been corrected. Circuits are recurring such that the LED shall flash and the horn sound, should another fault occur even prior to correction of the initial fault.

Georgia
1395 S. Marietta Pkwy SE,
Suite 218
Marietta, Georgia 30067

Missouri
2031 Adams Road
Sedalia, MO 65301

Texas
1616 FM 1960 West
Suite 750
Houston, Texas 77090

ProEnergy Services de Venezuela C.A.
Urbanización Los Caobos, Paseo Colón,
Torre Polar Oeste, Piso 4, Oficina 4-C
Plaza Venezuela - Caracas
Venezuela





XQ2000 SOUND ATTENUATED POWER MODULE 60HZ

STANDARD CONTROLS (continued):

Emergency Stop Pushbutton

Mushroom head, twist to reset, causes engine shutdown and tripping of the generator circuit breaker. Prevents engine starting when depressed.

Manual Paralleling

Controls consisting of reverse power relay, synchronizing lights, and switch. Reverse power condition causes tripping of the generator circuit breaker, immediate engine shutdown, flashing of indicating lamp, and sounding of alarm horn.

Circuit Breaker

Fixed mounted, three-pole, manually operated, molded case circuit breaker with solid state trip unit for overload (time overcurrent) and fault (instantaneous) protection. Includes DC shunt trip coil activated on any generator set monitored fault. Circuit breaker is sized for full load capacity of the generator set at 0.8 power factor.

Load Share Governor

Electronic load sharing governor with speed adjust potentiometer, idle/rated switch, and isochronous/droop switch.

Voltage Regulator

Standard Caterpillar generator-mounted digital voltage regulator with voltage adjust rheostat mounted in the floorstanding switchgear.

Current Transformers (3)

Five-ampere secondary with shorting terminal strips

Potential Transformers (3)

120 VAC secondary with primary and secondary fuse protection, two connected to the generator side of the circuit breaker, one connected to the load side of the circuit breaker.

Bus Bars

Three-phase plus fully rated neutral bus bars with NEMA standard hole pattern for connection of customer load cables and generator cables. Bus bars are sized for full load capacity of the generator set at 0.8 power factor. Also includes ground bus, connected to the generator frame ground and container frame with holes for connection of field ground cable. Bus bars are accessible from outside of the power module via hinged, lockable cable access door.

Accessory Power

3500 Power Modules

Three 230 VAC (50 Hz units) or 120 VAC (60 Hz units) shore power connections for jacket water heaters, generator space heater, and battery charger.

Battery Charger

24 VDC/20A battery charger with float/equalize modes and charging ammeter.

Georgia
1395 S. Marietta Pkwy SE,
Suite 218
Marietta, Georgia 30067

Missouri
2031 Adams Road
Sedalia, MO 65301

Texas
1616 FM 1960 West
Suite 750
Houston, Texas 77090

ProEnergy Services de Venezuela C.A.
Urbanización Los Caobos, Paseo Colón,
Torre Polar Oeste, Piso 4, Oficina 4-C
Plaza Venezuela - Caracas
Venezuela





Customer	Plant	Services	Equipment
	Gardner-Denver Facility	Electrical Component Change Out	
AES Corporation	Kelanitissa Project	Distributed Control System (DCS) Commissioning Support	1 X GE (GTG) Frame 9E
Alabama Municipal Electric Authority	Sylacauga Generating Project	Fuel gas filter separator installation	2 X GE (GTG) LM6000
Alabama Municipal Electric Authority	Sylacauga Generating Project	Installation of gas fuel filter for the inlet gas line	2 X GE (GTG) LM6000
Alcan Cable	Alcan Cable	Plant Lighting Retrofit and Ground Wiring	
Alcan Cable	Alcan Cable	Removal and replacement of bearings on stranders.	
Allegheny Energy	Allegheny Units 3, 4, & 5	Training session for upgraded distributed control system (DCS)	1 X Teleperm XP
Alliant Energy	Emery Generating Station	Site Specific Training and Operating Procedures	2 X GE (GTG) Frame 7FA
Alstom Power Environmental Systems	Marshall Steam Station FGD Addition Project	Site Quality Management including site inspection activities for the slip form erection of chimney and fiber glass fabrication of absorber ducts	2 X 2260 MW Coal-Fired Facility
Alstom Power Inc.	Doswell Limited	Mechanical Support Services for Front Standard Inspection	1 X Alstom (STG) DKZZ 186 Steam Turbine
Alstom Power Inc.	Frontera Generating Station	Mechanical Support Services for STG Valve Outage	1 X Alstom (STG) DKZZ 186 Steam Turbine
Alstom Power Inc.	H.W. Sundt Generating Station	Provide Westinghouse Technical Field Advisor	1 X Siemens-Westinghouse ST
Alstom Power Inc.	Duke Belews Creek	QA/QC Manager	
Alstom Power Inc.	Hugo Power Station	Technical Advisor	1 X Siemens-Westinghouse ST
Alstom Power Inc.	FPL Martin Generating Station	Westinghouse ST Technical Advisor	1 X Siemens-Westinghouse ST
Alstom Power Inc.	Gerald Gentlemen Generating Station	GE TFA	1 X 1362 MW Coal Fired Plant
Alstom Power Rentals	Tallahassee Project	Field service and operation support for rental power project including dismantling and demobilization of units	12 X Solar Taurus 60
Alstom Power Rentals	Vera Cruz Project	Field service and operation support for rental power project including troubleshooting and maintenance of the units	23 X Solar Taurus 60
Alyseka Pipeline Company	Pump Station Number 9	Start Up Audit Consultant	1 X Alaska Pipeline Pump Station
Ameren Energy Generating	Grand Tower Generating Station	Borescope inspections of gas turbines	2 X Siemens-Westinghouse GTG W501F
Ameren Energy Generating	Duck Creek Power Station	DCS Specialist	1 X 441 MW Coal Fired Steam Turbine
Ameren Energy Generating	Duck Creek Power Station	FGD Electrical & Mechanical Startup Engineers	1 X 441 MW Coal Fired Steam Turbine



Customer	Plant	Services	Equipment
Ameren Energy Generating	Various	First Out of Ground Gas Valves Installation	
Ameren Energy Generating	Grand Tower Generating Station	Teleperm TXP Distributed Control System (DCS) Training	2 X Siemens-Westinghouse GTG W501F
Ameren Energy Generating	Duck Creek Power Station	Turnover Coordinator	1 X 441 MW Coal Fired Steam Turbine
Ameren Energy Generating	Edwards Power Station	CWI	
Ameren Energy Generating	Grand Tower Generating Station	W501FD2 Hot Gas Path parts	48 X Ring Segment
Ameren Services	Duck Creek Power Station	Electrical Commissioning Engineer	1 X 441 MW Coal Fired Steam Turbine
Ameren UE	Pickneyville Power Plant	4 Year Operations and Maintenance Contract	4 X GE (GTG) LM6000;#7;#GE (GTG) Frame 6B
Ameren UE	Raccoon Creek Energy Center	4 Year Operations and Maintenance Contract	4 X GE (GTG) Frame 7EA
Ameren UE	Goose Creek Energy Center	4 Year Operations and Maintenance Contract	6 X GE (GTG) Frame 7EA
Ameren UE	Audrain Power Plant	4 Year Operations and Maintenance Contract	8 X GE (GTG) Frame 7EA
Ameren UE	Kinmundy Power Plant	4 Year Operations and Maintenance Contract	2 X Siemens-Westinghouse GTG W501D5A
Ameren UE	Fairgrounds CTG	Borescope Inspection	1 X GE (GTG) Frame 7B
Ameren UE	Mexico CTG	Borescope Inspection	1 X GE (GTG) Frame 7B
Ameren UE	Moberly CTG	Borescope Inspection	1 X GE (GTG) Frame 7B
Ameren UE	Moreau CTG	Borescope Inspection	1 X GE (GTG) Frame 7B
Ameren UE	Peno Creek Power Plant	Borescope inspection	8 X Pratt & Whitney FT8
Ameren UE	Venice Power Plant	Borescope Inspection	2 X Siemens-Westinghouse GTG W501F;#212;#Siemens-Westinghouse GTG W501D;#74;#Pratt & Whitney FT8
Ameren UE	Venice and Peno Creek	Borescope Inspection	10 X Pratt & Whitney FT8
Ameren UE	Venice Power Plant	Borescope Inspections Units 3 & 4	2 X Siemens-Westinghouse GTG W501F;#212;#Siemens-Westinghouse GTG W501D;#74;#Pratt & Whitney FT8
Ameren UE	Duck Creek Power Station	Certified Welding Inspector	1 X GE (STG)
Ameren UE	Audrain Power Plant	Change out of Water Injection Gear Box	8 X GE (GTG) Frame 7EA
Ameren UE	Duck Creek Power Station	Commissioning Superintendent	
Ameren UE	Edwards Power Station	Commissioning Superintendent	
Ameren UE	Kinmundy Power Plant	Craft labor for combustion inspection of gas turbine units	2 X Siemens-Westinghouse GTG W501D5A
Ameren UE	Fairgrounds CTG	CTG Controls Upgrade	1 X GE (GTG) Frame 7B
Ameren UE	Dispatch Center	Dispatch Center Operators	1 X Remote Dispatch Unit Operations



Customer	Plant	Services	Equipment
Ameren UE	Raccoon Creek Energy Center	Evaporative Cooler Media Replacement	4 X GE (GTG) Frame 7EA
Ameren UE	Goose Creek Energy Center	Exhaust Repairs	6 X GE (GTG) Frame 7EA
Ameren UE	Fairgrounds CTG	Expansion Joints Replacement	1 X GE (GTG) Frame 7B
Ameren UE	Moberly CTG	Expansion Joints Replacement	1 X GE (GTG) Frame 7B
Ameren UE	Duck Creek Power Station	FGD Construction Supervisor	1 X 441 MW Coal Fired Steam Turbine
Ameren UE	Duck Creek Power Station	FGD Startup & Commissioning Manager	1 X 441 MW Coal Fired Steam Turbine
Ameren UE	Venice Power Plant	FT8 gas generator removal, shipping and installation	2 X Siemens-Westinghouse GTG W501F
Ameren UE	Peno Creek Power Plant	FT8 Power Turbine Reinstallation	8 X Pratt & Whitney FT8
Ameren UE	Peno Creek Power Plant	FT8 Power Turbine Removal	8 X Pratt & Whitney FT8
Ameren UE	Corporate Head Quarters	Gas Turbine Consultant	1 X GE (GTG) LM6000
Ameren UE	Kinmundy Power Plant	Generator Blades Replacement	2 X Siemens-Westinghouse GTG W501D5A
Ameren UE	Raccoon Creek Energy Center	Generator exciter bearing seals replacement	4 X GE (GTG) Frame 7EA
Ameren UE	Pickneyville Power Plant	Heat Exchange Cleaning	4 X GE (GTG) LM6000
Ameren UE	Audrain Power Plant	Heat Exchanger #1 Maintenance	8 X GE (GTG) Frame 7EA
Ameren UE	Audrain Power Plant	Heat Exchanger #3 Maintenance	8 X GE (GTG) Frame 7EA
Ameren UE	Hutsonville Power Station	I&C/DCS Scheduler	
Ameren UE	Pickneyville Power Plant	Inlet Chiller Vent Installation	4 X GE (GTG) LM6000
Ameren UE	Audrain Power Plant	Inlet Filter House Screens Fabrication & Installation	8 X GE (GTG) Frame 7EA
Ameren UE	Audrain Power Plant	Install Demin water interconnect piping	8 X GE (GTG) Frame 7EA
Ameren UE	Pickneyville Power Plant	Mechanical repair on exhaust systems to implement OEM product bulletins	4 X GE (GTG) Frame 6B
Ameren UE	Duck Creek Power Station	Mechanical Superintendent	1 X GE (STG)
Ameren UE	Kinmundy Power Plant	Modified Hot Gas Path Inspection	2 X Siemens-Westinghouse GTG W501D5A
Ameren UE	Edwards Power Station	Outage Project Manager	3 X Front Fired LNB Coal Fired Power Plant
Ameren UE	Venice Power Plant	Owners Representative	2 X Siemens-Westinghouse GTG W501F
Ameren UE	Duck Creek Power Station	Planner/Scheduler	
Ameren UE	Pickneyville Power Plant	Planner/Scheduler	
Ameren UE	Pickneyville Power Plant	Plant Cleanup Support	4 X GE (GTG) LM6000
Ameren UE	Peno Creek Power Plant	Pratt & Whitney Service Bulletin 05B03 Implementation	8 X Pratt & Whitney FT8
Ameren UE	Venice Power Plant	Pratt & Whitney Service Bulletin 05B03 Implementation	2 X Pratt & Whitney FT8



Customer	Plant	Services	Equipment
Ameren UE	Venice Power Plant	Provide assessment of Westinghouse 301G GTG	
Ameren UE		Relay Testing Documentation	
Ameren UE	Duck Creek Power Station	Schedulers	
Ameren UE	Various, St. Louis	Technical Advisor	
Ameren UE	Kinmundy Power Plant	Discharge Flange Gasket Replacement	2 X Siemens-Westinghouse GTG W501D5A
Ameren UE	Pickneyville Power Plant	Cleaning Heat Exchangers	4 X GE (GTG) Frame 6B
Aquila, Inc.	Lake Road Generating Station	Critical Combustion Turbine System Review	1 X Siemens-Westinghouse GTG 501B
Aquila, Inc.	South Harper Peaking Facility	Install 3 Siemen's Westinghouse Generators	3 X Siemens-Westinghouse GTG W501D
Aquila, Inc.	South Harper Peaking Facility	Peaking Operators and Controls	3 X Siemens-Westinghouse STG 251
Aquila, Inc.	Greenwood Energy Center	Project Manager	
Aquila, Inc.	Lake Road Generating Station	Training Services	2 X Pratt & Whitney FT4A9
Aquila, Inc.	Greenwood Energy Center	Training services for A GE 7B Gas Turbine	4 X GE (GTG) Frame 7B
Aquila, Inc.	Ralph Green Plant	Training Services for A GE 7E Gas Turbine	1 X GE (GTG) Frame 7E
Aquila, Inc.		Operating Technicians	
ARB, Inc.		CWI	
ARB, Inc.		CWI	
ARB, Inc.		CWI	
ARB, Inc.		CWI	
ARB, Inc.	N/A Boron	Field Engineer	
ARB, Inc.		QA/QC Inspector	
ARB, Inc.		QA/QC Manager	
ARB, Inc.		QA/QC Manager	
ARB, Inc.	N/A Antioch	QA/QC Manager	
ARB, Inc.	N/A Antioch	Safety Manager	
ARB, Inc.		Scheduler	
ARB, Inc.	N/A Antioch	Safety Manager	
ARB, Inc.		Safety Manager	
ARB, Inc.		Safety Manager	
Arkansas Electric	Wrightsville Generating Station	Borescope and External Inspection of GE 7EA	6 X GE (GTG) LM6000:#18;#GE (GTG) Frame 7EA:#31;#GE (STG) D Series
Arkansas Electric	Wrightsville Generating Station	Borescope and External Inspection of GE LM6000's and GE Frame 7EA	6 X GE (GTG) LM6000:#18;#GE (GTG) Frame 7EA:#31;#GE (STG) D Series



Customer	Plant	Services	Equipment
Arkansas Electric	Fitzhugh Power Plant	Outage Technical Advisor	1 X Siemens-Westinghouse GTG W501D5A
Associated Electric Cooperative Inc.	New Madrid Power Station	Boiler Repair Support	2 X Alstom (STG)
Associated Electric Cooperative Inc.	Holden Power Plant	Electrical Maintenance	3 X Siemens-Westinghouse GTG V84.2
Associated Electric Cooperative Inc.	Holden Power Plant	Mechanical Maintenance	3 X Siemens-Westinghouse GTG V84.2
Associated Electric Cooperative Inc.	Essex Power Plant	Replace Row 4 turbine lock plate and securing screws; Siemens Technical Advisory 2006-008	1 X Siemens-Westinghouse GTG W501D5A
Associated Electric Cooperative Inc.	Unionville Power Plant	Torque Electric Removal/ Reinstallation Support	1 X GE (GTG) Frame 5
AZCO, Inc.	Mitchell Power Station Facility	Project Coordinator Support Specialist	1 X 1632.6 MW Coal Fired Plant
AZCO, Inc.	Mankato Power Project	QA/QC Manager	2 X GE (GTG) Frame 7FA
AZCO, Inc.	Council Bluffs Power Station	QA/QC Manager	
AZCO, Inc.	Power Iowa	Technical Advisor for the centerline erection of the steam turbine	1 X GE (STG) D Series
AZCO, Inc.		Technical Advisor Services for centerline installation including scheduling and installation sequencing	3 X Siemens-Westinghouse GTG W501D5A
Bahia de Bizkaia Electricidad, S.A.	B.P. Amoco Bahia de Bizkaia Electricidad, S.L.	Operations and Maintenance Audit	1 X GE (GTG) Frame 9FA
Bahia de Bizkaia Electricidad, S.A.	B.P. Amoco Bahia de Bizkaia Electricidad, S.L.	Start-up	1 X GE (GTG) Frame 9FA
Balkan Energy	Effasu Power Barge	Startup & Commissioning	2 X Siemens-Westinghouse GTG V64.3A
BGB Power	The Power Barge	Equipment Condition Assessment	4 X Pratt & Whitney FT8
Big Sandy Peaker Plant	Big Sandy Peaker Plant LLC	Collector Box Service Bulletins 05M05, 06M06 & 97M03	12 X Pratt & Whitney FT8
Big Sandy Peaker Plant	Big Sandy Peaker Plant LLC	Pratt & Whitney Service Bulletin 05B03 Implementation	6 X Pratt & Whitney FT8
Black & Veatch Corporation	AES Kelanitissa Project	Civil Superintendent - Pedestal Repair on a Westinghouse Steam Turbine	1 X Siemens-Westinghouse ST
Black & Veatch Corporation	Cardinal Power Station	Civil/Structural Superintendent	1 X Alstom (STG);#102;#GE (STG)
Black & Veatch Corporation	Confidential	Due Diligence Support Services	
Black & Veatch Corporation	Various, Mid-West & Mid Atlantic	Due Diligence Support Services	1 X Diesel Generator Set
Black & Veatch Corporation	C R Lowman Power Station	Field Engineer Manager	3 X GE (STG)
Black & Veatch Corporation	Mid-American George Neal Energy Center	Plant walk down and updating of P&ID's to "as built" configuration	1 X Unit 1



Customer	Plant	Services	Equipment
Black & Veatch Corporation	AEC Lowman Superstructures	Subcontracts Administrator	3 X GE (STG)
Black Hills Generation	Wygen II Project	Electrical Start Up Engineer	1 X 100 MW Coal Fired Plant STG
Black Hills Generation	Wygen II Project	I&C Start Up Engineer	
Black Hills Generation	Wygen II Project	Mechanical Start Up Engineer	1 X 100 MW Coal Fired Plant STG
Black Hills Generation	Wygen II Project	Start Up Management	1 X 100 MW Coal Fired Plant STG
Brown's Equipment Trader LLC	EPC Support	ECP Support Services	
BTEC Turbines	Mulla Project	Instrumentation and Controls Engineering support for the commissioning and operational tuning of the gas turbines and balance of plant equipment.	12 X GE (GTG) Frame 5
Burns & McDonnell	Sinclair Refinery	Construction Support Services (P3 Scheduler and Mechanical Superintendents)	
Burns & McDonnell	Power Iowa	Electrical, Mechanical Superintendent, and Piping Construction Supervision for the installation of the gas turbine, steam turbine, HRSG, and balance of plant equipment.	2 X GE (GTG) Frame 7FA
Burns & McDonnell	Jeffrey Energy Center	Planner/Scheduler	3 X Allis Chalmers
Burns & McDonnell	South Texas Electric Co-op Project	Quality Assurance and Quality Control oversight for the installation of the gas turbine, steam turbine, and balance of plant equipment.	3 X GE (GTG) LM6000
Burns & McDonnell		Electrical Superintendent	
Burns & Roe	Dell Power Plant	Mechanical Start-up Engineer	2 X GE (GTG) Frame 7FA
Burns & Roe	Burns & Roe	Mechanical Superintendent	
CalEnergy/Power Resources Ltd.	Charles R Wing Cogen	Combustion Inspection Unit 2	1 X GE (GTG) Frame 7EA
CalPeak Power LLC	Various. California	Services Bulletin 05B03 Implementation	10 X Pratt & Whitney FT8
Calpin Global Services Company, Inc.	Valladolid III	Technical Writing Support Services	
Calpine	Corpus Christi	Developed and implemented the control logic for the distributed control system (DCS) and re-commissioned auxiliary boiler related controls.	1 X Teleperm XP
Calpine	Aries Power Plant	Developed and implemented the on-site, plant specific Safety Program including training of other site personnel.	2 X Siemens-Westinghouse GTG W501F
Calpine	Deer Park Energy Center	Review of corrupted distributed control system (DCS) database including recommendations for repair and re-installation	1 X Teleperm XP



Customer	Plant	Services	Equipment
Calpine	Acadia Energy Center	Technical training on distributed control system (DCS).	1 X Teleperm XP
Calpine Corporation	Turlock Power Facility	Mechanical Start-up Services	1 X GE (GTG) Frame 7FA
Calpine Global Services	Valladolid III	Start Up Services	2 X GE (GTG) Frame 7FA
Calpine Operating Services	Los Esteros Critical Energy Facility	DCS Engineer	
Casey Industrial	Wygen II Project	Craft Labor for Installation	1 X 100 MW Coal Fired Plant STG
Central Iowa Power Cooperative	Summit Lake Generating Station	Generator Electrical Testing	2 X Siemens-Westinghouse GTG W251
Chillicothe Municipal Utilities	Chillicothe Municipal Utilities	Technical Advisor Support Services	1 X Pratt & Whitney FT4
City of Columbia	City of Columbia Unit #5	Major Inspection and Generator Testing	1 X Siemens-Westinghouse ST
City of Columbia	City of Columbia Unit #7	Major Inspection and Generator Testing	1 X Siemens-Westinghouse ST
City of Columbia	City of Columbia Unit #2	Turnkey Combustion Turbine Inspection	1 X Siemens-Westinghouse GTG 171
City of Corona	Clearwater Cogen	Operating Technicians (4)	1 X GE (GTG) LM2500
City of Odessa, Missouri	Odessa Municipal Power Plant	Craft Labor Support	
City of Odessa, Missouri	Odessa Municipal Power Plant	Technical Advisor	
City of Odessa, Missouri	Odessa Municipal Power Plant	Injector Overhaul Support	1 X Worthington SEH-7
City Utilities of Springfield	James River Power Station	Boiler Tube Removal and Replacement	1 X Front Fired OFA ESP CS
Clearbid	Calpine Site	Inspection Support Services	4 X Siemens-Westinghouse GTG W501F
Coen	Corporate Office	Development of QA/QC Manuals	1 X Duct Burners
Colorado Energy Management	Hardin Generation Station	Construction Completion and Commissioning Services. Provided Lead Electrical and Lead Mechanical	1 X 116 MW Pulverized Coal Conventional Boiler;#100;#Alstom (STG);#115;#Old Marchell Boiler
Comision Federal de Electricidad	Samalayuca II	Power Plant System Trainer/Start-up Engineer	1 X GE (GTG) Frame 7FA
Contra Costa Electric	N/A Carson	P5 Scheduler	
Control Center LLC	N/A Lakeland	I&C Technician	
Control Center LLC		I&C Technician	
Control Center LLC	Black Dog Power Plant	Installation and testing of Combustor Dynamic Monitoring System including all electrical and mechanical equipment and connections.	1 X Siemens-Westinghouse GTG W501F
Control Center LLC		I&C Technician	
CP Kelco	San Diego Facility	Development of Operating Procedures	1 X Solar Mars GT
Creative Mechanical Sourcing	N/A Burbank	Assesment Services	1 X Pratt & Whitney FT4A11;#97;#GC4-C1
CT Parts Co		Frame 6B Inspection	1 X GE (GTG) Frame 6B



Customer	Plant	Services	Equipment
Custom Energy	Alta Dena Dairy Cogeneration Project	Commissioning oversight services including turnover package and commissioning schedule development and implementation	1 X 3.1 MW Caterpillar Engine
Custom Energy		Construction Manager	
Dahlen, Berg, & Company	Faribault Energy Park	Temporary Operations	1 X GE (GTG) Frame 7FA
Dahlen, Berg, & Company	Minnesota River Station	Temporary Operations	1 X Siemens-Westinghouse GTG SGT5-8000H
Dairyland Power	LACBWR	Mechanical Engineer support for removal of the Reactor Pressure Vessel and Spent Fuel Removal	
Desert Power	Desert Power	Operational Performance Analysis and Qualifying Facility Calculations	2 X GE (GTG) Frame 6B
Dis-Tran Packaged Substations, LLC	Sprainbrook Project	Electrical Technical Support for the installation and commissioning of substation switchgear and protective relays	1 X H Frame Ring Tower
Dowans Holdings	Site A	Construction Services	1 X GE (GTG) LM6000;#143;#GE (GTG) TM2500
Dowans Holdings	Site A	EPC, Startup, Operations and maintenance	1 X GE (GTG) LM6000
Dowans Holdings	Site B	EPC, Startup, Operations and maintenance	1 X GE (GTG) TM2500
Dowans Holdings	Site A	Parts Supply	1 X GE (GTG) LM6000
DQ Holdings	Desert Power	20 Year Facilities Operation and Maintenance Services Contract	2 X GE (GTG) Frame 6B
DQ Holdings	Various, Houston	Development Support for Various Power Projects, CMMS Implementation, Borescope Inspection, Emissions and Combustion Tuning	1 X Varous
DQ Holdings	Desert Power	Site preparation for demolition of old equipment in preparation for combined cycle application	2 X GE (GTG) Frame 6B
Duke Energy	K-Gen Facility	Ground Grid Repairs	4 X GE (GTG) Frame 7FA
Duke Energy	Wheatland Generating Station	Modified Hot Gas Path Inspection	1 X Siemens-Westinghouse GTG W501D5A
Duke Energy	Wheatland Generating Station	Modified Hot Gas Path Inspection	1 X Siemens-Westinghouse GTG W501D5A
Durr Construction	Astoria Energy, Phase 1	Centerline Installation Management	2 X GE (GTG) Frame 7FA;#100;#Alstom (STG)
Durr Construction	Astoria Energy, Phase 1	QA/QC Manager	2 X GE (GTG) Frame 7FA
Durr Construction	Astoria Energy, Phase 1	Shipping and Receiving Manager	2 X GE (GTG) Frame 7FA
E. On. US	Waterside Facility	Facility Inspection Audit	4 X GE LM1500
Eastman Chemical Company	Eastman Co-Gen	Unit 1 Hot Gas Path with Bucket Replacement	1 X GE (GTG) Frame 7FA



Customer	Plant	Services	Equipment
Eastman Chemical Company	Eastman Co-Gen	Unit 2 Hot Gas Path with Bucket Replacement	1 X GE (GTG) Frame 7FA
EBF & Associates	Desert Power	Facility Audit Services	2 X GE (GTG) Frame 6B
Electrical Corporation of America Inc.	Cannon Falls Energy Center	EH&S Consultant	2 X GE (GTG) Frame 7FA
Electrical Corporation of America Inc.	Spindle Hill Energy Center	I & C Technicians	2 X GE (GTG) Frame 7FA
Enerfab	Asbury Superheat	CWI	
Enerfab	Neal Generating Station	CWI	
Enerfab	George Neal Generating Station	Project Manager	
Enxco	Goodnoe Hills Wind Project	Administrative Assistant	1 X MD70
Enxco	Goodnoe Hills Wind Project	Owner's Construction Representative	1 X MD70
Enxco	Fenton Windfarm	Owner's Construction Representative	1 X 205 MW Wind Farm
Enxco	N/A Dexter, MN	Owner's Representative	
Enxco	N/A Dexter, MN	Administrative Assistant Support Services	
Enxco	N/A	Sales Support Services	
Enxco		Owner's Construction Representative	
EPCO	Mid-Missouri Energy	Valves Installation	1 X 2" Check Valve
EPRI	Ebadrolla	GE 9FA GTOP	1 X GE (GTG) Frame 9FA
EPRI	N/A	GTOP Development	1 X GE (GTG) Frame 9FA
EUCI	EUCI Training Center	Training Services	
EUCI	EUCI Training Center	Training Services	
Florida Municipal Power Agency	Stock Island Power Station	CMMS Implementation	1 X GE (GTG) LM6000
Florida Power & Light	Blythe Energy Plant	Development of Procedures and Training Program on GEA Refrigeration System and Air Inlet Cooling	1 X GEA Refridgeration Unit
Florida Power & Light	Ft. Myers Station	Major Inspection	1 X GE (GTG) Frame 7B
Florida Power & Light	Cherokee Facility	Provide Instrument and Controls Technicians	1 X GE (GTG) Frame 6FA
FPL-Calhoun	Calhoun Energy Center	Broken Bolt Removal	4 X GE (GTG) Frame 7FA
FPL-Calhoun	Calhoun Energy Center	Cooling Water Pump Repair	4 X GE (GTG) Frame 7FA
FPL-Calhoun	Calhoun Energy Center	Craft Labor Maintenance Support	4 X GE (GTG) Frame 7FA
FPL-Calhoun	Calhoun Energy Center	Generator Energy Turning Gear Coupling Change Out	3 X GE (GTG) Frame 7FA
Frank W. Hake, Inc.	Marcus Hook Power Project	Material Controller and Quality Manager	3 X GE (GTG) Frame 7FA
Frank W. Hake, Inc.	Marcus Hook Power Project	Steam Turbine Specialist	3 X GE (GTG) Frame 7FA



Customer	Plant	Services	Equipment
GE Energy	Southern Cali Edison (various sites)	Start-up Support	
GE International, Inc.	Hsiu Tao	Training to support the operations of the gas turbines, steam turbine, and balance of plant equipment.	3 X GE (GTG) Frame 7FA
GE International, Inc.		Installation & Commissioning for 1 X LM2500 = CLE Packages and Limited BOP Equipment	1 X GE (GTG) LM2500
Generadora del Atlantico	Termo Colon Power Plant	Engineering Services	2 X GE (GTG) Frame 7B with auxiliaries
Generadora del Atlantico	Termo Colon Power Plant	Combined Cycle Equipment, Supervision, Technical Assistance and Management, Operations and Maintenance, Refurbishment and Reinstallation of Equipment	1 X GE (STG);#200;#Cooling Tower;#174;#Heat Exchanger;#250;#Electric Generator;#252;#Waste Water Treatment System;#253;#Equipment Substation;#251;#Auxiliary Equipment
Global Controls	N/A Yopal	DCS Engineer	
Global Controls	N/A Yopal	DCS Engineer Support Services	
Grand River Dam Authority	Grand River Dam Authority Coal Fired Complex	Spacer Cane Fabrication	100 X U-1 Primary SH Spacer Canes
Granite Ridge Energy LLC	Granite Ridge Energy Center	Troubleshooting, Repair, and Recommissioning of the Siemens Westinghouse Symadyn Turbine Controls System.	1 X Siemens-Westinghouse GTG W501G
Hayes Lemmerz	Hayes Lemmerz International Facility	Blue Dot/Control Box Relocate	
Hayes Lemmerz	Hayes Lemmerz International Facility	Build Control Logix PLC Panel & DC Drive Panel	
Hayes Lemmerz	Hayes Lemmerz International Facility	Column Weld Repairs	
Hayes Lemmerz	Hayes Lemmerz International Facility	Controls Cabinet Delivery	
Hayes Lemmerz	Hayes Lemmerz International Facility	Decline Elevator Fabrication	
Hayes Lemmerz	Hayes Lemmerz International Facility	Electrical Repairs - Damaged Disconnect	
Hayes Lemmerz	Hayes Lemmerz International Facility	Electrical Support	
Hayes Lemmerz	Hayes Lemmerz International Facility	Exit Conveyor Repair	
Hayes Lemmerz	Hayes Lemmerz International Facility	Fabricate & Install Flip Over Unit	
Hayes Lemmerz	Hayes Lemmerz International Facility	Fabricate & Install Wheel Stops	
Hayes Lemmerz	Hayes Lemmerz International Facility	Grating Installation	



Customer	Plant	Services	Equipment
Hayes Lemmerz	Hayes Lemmerz International Facility	Install S15 Conveyor P21 & P23	
Hayes Lemmerz	Hayes Lemmerz International Facility	Installation of Butt Welder Out Feed Chute	
Hayes Lemmerz	Hayes Lemmerz International Facility	Installation of Chute	
Hayes Lemmerz	Hayes Lemmerz International Facility	Lighting Installation	
Hayes Lemmerz	Hayes Lemmerz International Facility	Lighting Installation	
Hayes Lemmerz	Hayes Lemmerz International Facility	Matrix Area Floor Support	1 X S16 Conveyor System
Hayes Lemmerz	Hayes Lemmerz International Facility	Mechanical Support Services	
Hayes Lemmerz	Hayes Lemmerz International Facility	Metering Pump & Alarm Light Wiring	
Hayes Lemmerz	Hayes Lemmerz International Facility	Moore Gauges Installation	
Hayes Lemmerz	Hayes Lemmerz International Facility	Overhead Crane Maintenance	
Hayes Lemmerz	Hayes Lemmerz International Facility	Photo Eyes Installation	
Hayes Lemmerz	Hayes Lemmerz International Facility	Pipe Bollards Installation	
Hayes Lemmerz	Hayes Lemmerz International Facility	Raise S18 Spider Line	
Hayes Lemmerz	Hayes Lemmerz International Facility	Reject Wheel Shoot	
Hayes Lemmerz	Hayes Lemmerz International Facility	Rework/Replace S05 Butt Welder	1 X Teleperm XP
Hayes Lemmerz	Hayes Lemmerz International Facility	Roach CVC Conveyor Relocation	
Hayes Lemmerz	Hayes Lemmerz International Facility	Robot Installation	
Hayes Lemmerz	Hayes Lemmerz International Facility	S02 Bumper Plate Installation	
Hayes Lemmerz	Hayes Lemmerz International Facility	S02 Shear Alignment	
Hayes Lemmerz	Hayes Lemmerz International Facility	S11 Weld Control Field Wiring	
Hayes Lemmerz	Hayes Lemmerz International Facility	S11 Weld Control Panels	
Hayes Lemmerz	Hayes Lemmerz International Facility	S12 Control Panel Fabrication	



Customer	Plant	Services	Equipment
Hayes Lemmerz	Hayes Lemmerz International Facility	S12 Work Platform Install	
Hayes Lemmerz	Hayes Lemmerz International Facility	S15 Mist Collector motor change out	
Hayes Lemmerz	Hayes Lemmerz International Facility	S15 Prab Coolant Line Additional Supporting	
Hayes Lemmerz	Hayes Lemmerz International Facility	S15 Valve Hole Assembly Stamp	
Hayes Lemmerz	Hayes Lemmerz International Facility	S15 Valve Hole Exit Flip Over	
Hayes Lemmerz	Hayes Lemmerz International Facility	S16 Shot Peen Conveyor Line System Installation	
Hayes Lemmerz	Hayes Lemmerz International Facility	S16 Welder Spider Line	
Hayes Lemmerz	Hayes Lemmerz International Facility	Safety Guarding Installation	
Hayes Lemmerz	Hayes Lemmerz International Facility	Safety Guarding S15 Elevator	
Hayes Lemmerz	Hayes Lemmerz International Facility	Topcoat Electrical Support	
Hayes Lemmerz	Hayes Lemmerz International Facility	Verson 3 Chute Repair	
Hayes Lemmerz	Hayes Lemmerz International Facility	Weld Repair Booth Conveyor Rework	
Hayes Lemmerz	Hayes Lemmerz International Facility	Weld Repsir Booth Conveyer Retrofit	
Hayes Lemmerz	Hayes Lemmerz International Facility	Wheel Wash & Dryer Piping Installation	
Hayes Lemmerz	Hayes Lemmerz International Facility	Wheelabrator Shot Seperation Piping	
Hayes Lemmerz	Hayes Lemmerz International Facility	Guard Rail Fabrication	
Hayes Lemmerz	Hayes Lemmerz International Facility	S-14 Welder Repairs	
Hayes Lemmerz	Hayes Lemmerz International Facility	S17 Floor Stops	
Hayes Lemmerz	Hayes Lemmerz International Facility	Overhead Crane Maintenance	
Hayes Lemmerz	Hayes Lemmerz International Facility	Overhead Crane Maintenance	
Hayes Lemmerz	Hayes Lemmerz International Facility	S07 Trimmer Clamp Cylinder Mount	
Hayes Lemmerz	Hayes Lemmerz International Facility	Kidney Loop Electrical	



Customer	Plant	Services	Equipment
Hayes Lemmerz	Hayes Lemmerz International Facility	Robot Stands Fabrication	2 X Robot Stands
Hess Microgen	Ellihu Harris	Installation, configuration and testing of electrical protection relays.	3 X Combined Heat and Power 200 kW
Hess Microgen	Malta Bend Ethanol Facility	24- 100 lbs of garnett	1 X Ethanol Refinery Plant
Hess Microgen	Bay Ridge	Construction completion and punch list resolution for final client acceptance on engines, generator and control system.	2 X Combined Heat and Power 200 kW
Hess Microgen	Colt Arms Project	Construction completion and punch list resolution for final client acceptance on engines, generator and control system.	1 X Combined Heat and Power 200 kW
Hess Microgen	Corporate Energy Investing	Construction completion and punch list resolution for final client acceptance on engines, generator and control system.	4 X Combined Heat and Power 200 kW
Hess Microgen	Ellihu Harris	Construction completion and punch list resolution for final client acceptance on engines, generator and control system.	3 X Combined Heat and Power 200 kW
Hess Microgen	London Terrace	Construction completion and punch list resolution for final client acceptance on engines, generator and control system.	2 X Combined Heat and Power 200 kW
Hess Microgen	Agua Caliente /Spa Casino	Construction completion and punch list resolution for final client acceptance on engines, generator and control system.	1 X Combined Heat and Power
Hess Microgen	VSQ	Construction completion and punch list resolution for final client acceptance on engines, generator and control system.	1 X Combined Heat and Power
Hess Microgen	Davis Retirement Home	Construction completion and punch list resolution for final client acceptance on engines, generator and control system.	1 X Combined Heat and Power 375 kW
Hess Microgen	New Yorker Hotel	Construction completion and punch list resolution for final client acceptance on engines, generator and control system.	2 X Back Up Power 320 kW
Hess Microgen	Fairfield Dye	Construction completion and punch list resolution for final client acceptance on engines, generator and control system.	2 X Combined Heat and Power 200 kW
Hess Microgen	San Francisco Civic Center	Construction completion and punch list resolution for final client acceptance on engines, generator and control system.	4 X Combined Heat and Power 200 kW
Hess Microgen	Favorite Plastics	Construction completion and punch list resolution for final client acceptance on engines, generator and control system.	1 X Combined Heat and Power
Hess Microgen	Network Appliances	Construction completion and punch list resolution for final client acceptance on engines, generator and control system.	6 X Combined Heat and Power



Customer	Plant	Services	Equipment
Hess Microgen	Oaks Christian Academy	Construction completion and punch list resolution for final client acceptance on engines, generator and control system.	1 X Combined Heat and Power
Hess Microgen	Pacific Choice Brands	Construction completion and punch list resolution for final client acceptance on engines, generator and control system.	1 X Combined Heat and Power
Hess Microgen	Regency	Construction completion and punch list resolution for final client acceptance on engines, generator and control system.	1 X Combined Heat and Power
Hess Microgen	San Luis Obispo County Court House	Construction completion and punch list resolution for final client acceptance on engines, generator and control system.	1 X Combined Heat and Power
Hess Microgen	Sunkist	Construction completion and punch list resolution for final client acceptance on engines, generator and control system.	3 X Combined Heat and Power
Hess Microgen	Sunkist Tank Farm	Construction completion and punch list resolution for final client acceptance on engines, generator and control system.	6 X Combined Heat and Power
Hess Microgen	Metropolis Towers	Construction completion and punch list resolution for final client acceptance on engines, generator and control system.	2 X Combined Heat and Power 200 kW
Hess Microgen	Corporate Procedures and Training Development	Development of Corporate Procedures and Manuals (Administrative, EH&S, Maintenance, Computerized Maintenance Management System, Logistics (SAP), Training for Field Service Teams (Level 1 Operator and Advanced Maintenance), Engineering Design Process	1 X Combined Heat and Power
Hess Microgen	Davis Retirement Home	Installation, configuration and testing of electrical protection relays.	1 X Combined Heat and Power 375 kW
Hess Microgen	New Yorker Hotel	Installation, configuration and testing of electrical protection relays.	2 X Back Up Power 320 kW
Hess Microgen	Bay Ridge	Installation, configuration and testing of electrical protection relays.	2 X Combined Heat and Power 200 kW
Hess Microgen	Colt Arms Project	Installation, configuration and testing of electrical protection relays.	1 X Combined Heat and Power 200 kW
Hess Microgen	Corporate Energy Investing	Installation, configuration and testing of electrical protection relays.	4 X Combined Heat and Power 200 kW
Hess Microgen	Fairfield Dye	Installation, configuration and testing of electrical protection relays.	2 X Combined Heat and Power 200 kW
Hess Microgen	London Terrace	Installation, configuration and testing of electrical protection relays.	2 X Combined Heat and Power 200 kW
Hess Microgen	Metropolis Towers	Installation, configuration and testing of electrical protection relays.	2 X Combined Heat and Power 200 kW
Hess Microgen	San Francisco Civic Center	Installation, configuration and testing of electrical protection relays.	4 X Combined Heat and Power 200 kW



Customer	Plant	Services	Equipment
Hess Microgen	Agua Caliente /Spa Casino	Installation, configuration and testing of electrical protection relays.	1 X Combined Heat and Power
Hess Microgen	Favorite Plastics	Installation, configuration and testing of electrical protection relays.	1 X Combined Heat and Power
Hess Microgen	Network Appliances	Installation, configuration and testing of electrical protection relays.	6 X Combined Heat and Power
Hess Microgen	Oaks Christian Academy	Installation, configuration and testing of electrical protection relays.	1 X Combined Heat and Power
Hess Microgen	Pacific Choice Brands	Installation, configuration and testing of electrical protection relays.	1 X Combined Heat and Power
Hess Microgen	Regency	Installation, configuration and testing of electrical protection relays.	1 X Combined Heat and Power
Hess Microgen	San Luis Obispo County Court House	Installation, configuration and testing of electrical protection relays.	1 X Combined Heat and Power
Hess Microgen	Sunkist	Installation, configuration and testing of electrical protection relays.	3 X Combined Heat and Power
Hess Microgen	Sunkist Tank Farm	Installation, configuration and testing of electrical protection relays.	6 X Combined Heat and Power
Hess Microgen	VSQ	Installation, configuration and testing of electrical protection relays.	1 X Combined Heat and Power
Hess Microgen	Desert Power	Major Inspection. Rotors pulled and shipped for refurbishment	2 X GE (GTG) Frame 6B
Hess Microgen		Managed Service departments evaluating service levels, cost, and productivity.	
Hess Microgen	PADEP	Project Management, field engineering, and installation of a cogeneration plant providing power, chilled water, hot water, and heat sink for the laboratory.	6 X Combined Heat and Power 375 kW
Hess Microgen	Westin Maui	Project Management, field engineering, and installation of a cogeneration plant.	1 X Combined Heat and Power 515 kW
Hess Microgen	St. Regis	Project Management, field engineering, and installation of a cogeneration plant.	1 X Combined Heat and Power 375 kW
Hess Microgen	Fairmont Orchid	Project Management, field engineering, and installation of a cogeneration plant.	1 X Combined Heat and Power
Hess Microgen	KOR	Project Management, field engineering, and installation of a cogeneration plant.	1 X Combined Heat and Power
Hess Microgen	Agua Fria Generation Station	Project management, turnkey estimate and proposal development, and feasibility of backup generation to be installed in the basement of the building.	1 X Back Up Power 320 kW
Hess Microgen	Agua Caliente /Spa Casino	Project Management, turnkey estimate and proposal development, and feasibility of CHP to be installed on the 11th floor offset roof.	1 X Combined Heat and Power 375 kW



Customer	Plant	Services	Equipment
Hess Microgen	Jewish Home & Hospital	Project management, turnkey estimate and proposal development, and feasibility of CHP.	1 X Cogeneration Units Ranging from 200 kW to 1.2 MW
Hess Microgen	Advanced Maintenance Training Course	Technical Training including classroom and on the job (OJT) sessions.	1 X Combined Heat and Power
Hess Microgen	Fundamentals Training Course	Technical Training including classroom and on the job (OJT) sessions.	1 X Combined Heat and Power
Hess Microgen	Interstate Brands	Turn-key installation of a combined heat and power plant (CHP) including all civil, mechanical, electrical and control work.	1 X Package Boiler
Hess Microgen	Various 13 Locations	Complete Asset Management Services	1 X Cogeneration Units Ranging from 200 kW to 1.2 MW
Hill International Ltd.	Government of Iraq	TXP Control System Training	
Hitachi America Ltd.	Mid-American Unit 4	Assistant Start Up Supervisor	
Hitachi America Ltd.	Mid-American Unit 4	DCS Engineer	
Hitachi America Ltd.	Mid America Project	DCS Start Up Engineering Support Services	
Holland Energy	Holland Energy Center	Steam Turbine Electrical Testing	
Holland Energy	Holland Energy Center	Steam Turbine Mechanical Support	
IBT, Inc.	Gardner-Denver Facility	Conveyor Mechanical & Electrical Modifications	
IBT, Inc.	Hayes Lemmerz International Facility	Conveyor Pickup and Delivery	
ICM, Inc.	Andersons Greenville	Installation of Quad Dryer System	
ICM, Inc.	US Biofuels	Shutdown Support	
ICM, Inc.	Show Me Ethanol Facility	Underground Piping in Process Building and Energy Center	
ICM, Inc.	US Bio-Energy II	Dryer Installation	
ICM, Inc.	US Bio-Energy II	Installation of T/O	
ICV	Valladolid III	Turn Over Coordinator	2 X GE (GTG) Frame 7FA
ICV	Greenfield Energy Center	Turnover Coordinator	
Industrial Instruments, Inc.	N/A Cheyenne	I & C Technicians	
Interstate Brands	Pamona Facility	CHP Heat Balance and Incentive Program Assistance	2 X Hess 375;#180;#Hess 200;#181;#Hess HRSG 15 PSIG
Interstate Power & Light (Alliant)	Power Iowa	Developed and implemented a complete Combined Cycle Operator Training Course including training guides, classroom instruction, and on-the-job training.	2 X GE (GTG) Frame 7FA
Interstate Power & Light (Alliant)	Power Iowa	Developed complete set of Operations Procedures.	2 X GE (GTG) Frame 7FA
Irwin Industries	Various. California	Document Controls Specialist	1 X GE (GTG) LM6000
Irwin Industries	Various. California	Field Engineer	1 X GE (GTG) LM6000



Customer	Plant	Services	Equipment
Irwin Industries	Various. California	Field Engineer	1 X GE (GTG) LM6000
Irwin Industries	Various. California	Material Coordinator	1 X GE (GTG) LM6000
Irwin Industries	Various. California	Project Engineer	1 X GE (GTG) LM6000
Irwin Industries	Various. California	QA/QC Specialist	1 X GE (GTG) LM6000
Irwin Industries	Various. California	QA/QC Specialist	1 X GE (GTG) LM6000
Johnson Controls	Grace Power Plant	Controls Troubleshooting	1 X Siemens-Westinghouse ST
Johnson Controls	Grace Power Plant	Development of Operating Procedures	1 X Siemens-Westinghouse ST
Johnson Controls	Grace Power Plant	Installation of Generator Partial Discharge Analysis equipment	1 X Siemens-Westinghouse ST
Keys Energy Services	Stock Island Power Station	Fin Fan Cooler Installation	2 X Fairbanks Morse 18 PC2.6 Medium Speed Diesel Engine Generator
Keys Equipment Services	Stock Island Power Station	CMMS Implementation	2 X GE (GTG) Frame 5
Keys Equipment Services	Stock Island Power Station	CMMS Implementation	1 X Generator Sets and Auxiliary Equipment
Kiewit Industrial Company	Greater Des Moines Energy Center	Operations Supervision in support of the commissioning and startup of the facility including the training of the permanent plant operations staff	2 X Siemens-Westinghouse GTG W501F
Kiewit Industrial Company	LADWP Valley Generating Station	Provided Distributed Control System Specialist to support the commissioning of the gas turbines, steam turbine, and balance of plant equipment.	1 X Siemens-Westinghouse GTG W501F
Kinder Morgan CO2 Company	EG178 Power Plant	Start-up Manager and Commissioning Services including Schedule Development, System Scoping, Turnover Package Development and Implementation.	2 X GE (GTG) LM6000
L.K Comstock		Administrative Project Support	
LG&E	Gordonsville Energy Facility	Provided supervision, labor and tools for a Combustion Inspection	1 X GE (GTG) Frame 7EA
Longacre Management LP	Desert Power	Due Diligence	2 X GE (GTG) Frame 6B
Longacre Management LP	N/A Louisville	Due Diligence	
LSP Energy Limited Partnership	LSP Energy Batesville Facility	Loop Verification and MOV Limit Travel Settings	
MAN Ferrostaal	Termozulia Power Station	Combined Cycle Operators	
Marshall Municipal Utilities	Marshall Power Plant	Generator Electrical Testing	1 X Siemens-Westinghouse GTG W191
Marshall Municipal Utilities	Marshall Municipal Utilities Project	Performed Steam Turbine Outage including provision of the Technical Advisor, performance of Generator Relay Protection System Testing.	1 X GE (STG)
Marshall Municipal Utilities	Marshall Power Plant	Technical direction for major inspection of gas turbine	



Customer	Plant	Services	Equipment
MidAmerican Energy Company	Neal Generating Station	P3 Scheduling Services	1 X Opposed-Fired SCR LND Coal Fired Power Plant
MidAmerican Energy Company	Walter Scott Jr. Energy Center	Planner/Scheduler	1 X PC Opposed Fire Coal Fired Power Plant
MidAmerican Energy Company	Louisa Generating Station	Steam Turbine Project Manager	1 X 738.1 MW Siemens Westinghouse Subbiuminous Steam Turbine
Mid-Missouri Energy	Malta Bend Ethanol Facility	CMMS Implementation	1 X Ethanol Refinery Plant
Mid-Missouri Energy	Malta Bend Ethanol Facility	Extend DDG Blow Tube	
Mid-Missouri Energy	Malta Bend Ethanol Facility	Guard Rail Build	
Mid-Missouri Energy	Malta Bend Ethanol Facility	Hot Tap Pipe Work	
Mid-Missouri Energy	Malta Bend Ethanol Facility	Mechanical & Electrical Support Services	
Mid-Missouri Energy	Malta Bend Ethanol Facility	Mechanical Support	
Mid-Missouri Energy	Malta Bend Ethanol Facility	Mechanical Support Services for Outage	
Mid-Missouri Energy	Malta Bend Ethanol Facility	Wet Cake Expansion	
Mid-Missouri Energy	Malta Bend Ethanol Facility	Wet Cake Expansion Concrete Engineering	
Mirant	Dickerson Generating Station	Planner/Scheduler	1 X Tangential OFA LNB Coal Fired Power Plant
Mirant Sugar Creek LLC	Sugar Creek Project	Field Service technical support to support the installation and commissioning of the facility.	2 X GE (GTG) Frame 7FA
Mitsui Babcock	Sibley Power Station	Technical support to perform a site survey	1 X 523 MW Coal Fired Plant
MMC Corporation	Escondido Power Plant	Engine Change Out	2 X Pratt & Whitney FT4
MMC Corporation	Escondido Power Plant	Engine Change Out (Fall 2007)	2 X Pratt & Whitney FT4
MMC Corporation	Chula Vista and Escondido Power Plants	Instrument and Controls Verification	4 X Pratt & Whitney FT4
MMC Corporation	Chula Vista and Escondido Power Plants	Mechanical and I&C Support Services	4 X Pratt & Whitney FT4
MMC Corporation	Chula Vista and Escondido Power Plants	Oil Flush Services	
MMC Corporation	Chula Vista Power Plant	Operations and Maintenance	2 X Pratt & Whitney FT4
MMC Corporation	Escondido Power Plant	Operations and Maintenance	2 X Pratt & Whitney FT4
MMC Corporation	Chula Vista and Escondido Power Plants	Performance Test Preparations	4 X Pratt & Whitney FT4
MMC Corporation	Chula Vista and Escondido Power Plants	Re-Commissioning for Mothballed Units	4 X Pratt & Whitney FT4
MMC Energy	Escondido Power Plant	Emergency Repairs	2 X Pratt & Whitney FT4
MMC Energy	Mid-Sun Power Plant	Nox Catalyst Change Out	1 X GE (GTG) LM2500
MMC Energy	Mid-Sun Power Plant	Nox Catalyst Change Out	1 X GE (GTG) LM2500
MMC Energy	Mid-Sun Power Plant	Operations and Maintenance	1 X GE (GTG) LM2500



Customer	Plant	Services	Equipment
MMC Energy	Chula Vista and Escondido Power Plants	Outage Support Service	
MMC Energy	Mid-Sun Power Plant	Outage Support Services	1 X GE (GTG) LM2500
MMC Energy	Chula Vista, Escondido, Mid-Sun	Outage Support	4 X Pratt & Whitney FT4
MMWEC	MMWEC Project	Outage With Bucket Replacement	1 X GE (GTG) Frame 7FA
MOL Pakistan Oil and Gas Co. B.V.		Flanged Spool Fabrication	
Montgomery L'Energia	Montgomery L'Energia Power Plant	Startup and Commissioning	1 X Rolls Royce Trent
Murphy Company	Rentech Facility	API Inspector	
Murphy Company	Power Iowa	Provided Piping Supervisor for the installation of various piping systems for the steam turbine and balance of plant equipment	2 X GE (GTG) Frame 7FA
Murphy Company	Rentech Facility	QA/CWI	
Murphy Company	Coffeen Power Plant	QA/QC Manager	2 X GE Tandem Compound Steam Turbine
Murphy Company	Coffeen Power Plant	Materials Manager	2 X GE Tandem Compound Steam Turbine
Nebraska Public Power District	Sheldon Station	Cyclone Burner Installation	2 X Siemens-Westinghouse Tandem-Compound STG
Nebraska Public Power District	Gerald Gentlemen Generating Station	Unit 1 & 2 tripper floor and silo washdown sytem supply and installation	1 X 1368 MW Coal Fired Power Plant
Newmont Ghana Gold Limited	Ghana Mining Reserve Power Plant	Operations and Maintenance	3 X Pratt & Whitney FT4
Newmont Ghana Gold Limited	Ghana Mining Reserve Power Plant	Start-up and commissioning	
Newmont Mining Corporation	Power Barge Project	Owner's Representative	3 X Pratt & Whitney FT4
Nooter/Eriksen	N/A Songkhla	Startup Manager	
Nordyne	Boonville Facility	Mechanical Support Services	
Northern California Power Agency	Middletown Geothermal Plants	Training Services	1 X Steam Turbine Support Equipment
Northwest Wind Partners LP	Goodnoe Hills Facility	Administrative Assistant	
Nour Communications Company	Dumar Project	Installation and Commissioning	4 X Caterpillar XQ2000 Package
Nour Communications Company	Sakaka 2 Project	Installation and Commissioning	4 X Caterpillar XQ2000 Package
Nour Communications Company	Sakaka 1 Project	Installation and Commissioning	15 X Caterpillar XQ2000 Package

Customer	Plant	Services	Equipment
Nour Communications Company	Faisaleyah Project	Installation and Commissioning	7 X Caterpillar XQ2000 Package
Nour Communications Company	Khaldeyah Project	Installation and Commissioning	7 X Caterpillar XQ2000 Package
Nour Communications Company	Rafha Project	Installation and Commissioning	7 X Caterpillar XQ2000 Package
Nour Communications Company	Hadad Project	Installation and Commissioning	4 X Caterpillar XQ2000 Package
Nour Communications Company	Alkamasin Project	Installation and Commissioning	10 X Caterpillar XQ2000 Package
Nour Communications Company	Alshurafa Project	Installation and Commissioning	6 X Caterpillar XQ2000 Package
Nour Communications Company	Dumar Project	Operations and Maintenance	4 X Caterpillar XQ2000 Package
Nour Communications Company	Sakaka 2 Project	Operations and Maintenance	4 X Caterpillar XQ2000 Package
Nour Communications Company	Sakaka 1 Project	Operations and Maintenance	15 X Caterpillar XQ2000 Package
Nour Communications Company	Faisaleyah Project	Operations and Maintenance	7 X Caterpillar XQ2000 Package
Nour Communications Company	Khaldeyah Project	Operations and Maintenance	7 X Caterpillar XQ2000 Package
Nour Communications Company	Rafha Project	Operations and Maintenance	14 X Caterpillar XQ2000 Package
Nour Communications Company	Hadad Project	Operations and Maintenance	4 X Caterpillar XQ2000 Package
Nour Communications Company	Alkamasin Project	Operations and Maintenance	10 X Caterpillar XQ2000 Package
Nour Communications Company	Alshurafa Project	Operations and Maintenance	3 X Caterpillar XQ2000 Package
Nour Communications Company	Sakaka 2 Project	Project Management	4 X Caterpillar XQ2000 Package
Nour Communications Company	Sakaka 1 Project	Project Management	15 X Caterpillar XQ2000 Package
Nour Communications Company	Faisaleyah Project	Project Management	7 X Caterpillar XQ2000 Package
Nour Communications Company	Dumar Project	Project Management	4 X Caterpillar XQ2000 Package
Nour Communications Company	Khaldeyah Project	Project Management	7 X Caterpillar XQ2000 Package
Nour Communications Company	Rafha Project	Project Management	14 X Caterpillar XQ2000 Package
Nour Communications Company	Hadad Project	Project Management	4 X Caterpillar XQ2000 Package



Customer	Plant	Services	Equipment
Nour Communications Company	Alkamasin Project	Project Management	10 X Caterpillar XQ2000 Package
Nour Communications Company	Alshurafa Project	Project Management	3 X Caterpillar XQ2000 Package
NRX Global Corporation	Gavin Power Station	System walk down and evaluation to support the implementation of a complete Computerized Maintenance Management System (CMMS)	2 X 1300 MW Coal Fired (Supercritical)
Oglethorpe Power	Sewell Creek Energy Facility	Distributed Control System (DCS) database review including upgrade/repair of corrupt data and system maintenance. DCS Tuner/Programmer	1 X Teleperm XP
Oklahoma Municipal Power Authority			
OnQuest Engineering	N/A Honolulu	Safety Manager	
Pacific Gas & Electric		Civil Technician	
Pacific Gas & Electric	N/A	Civil Technician	
Pacific Rim	Various Venezuela	Inventory & Inspection Services	1 X Siemens-Westinghouse GTG W501F
Pacific Rim	Various Venezuela	Relocation of Five Westinghouse 501F	5 X Siemens-Westinghouse GTG W501F
Pakistan Power Resources	Bhikhi Power Plant	Operations & Maintenance	3 X GE (GTG) LM6000
Pakistan Power Resources	Guddu Power Generation Plant	EPC; Balance of Plant; Refurbishment and Conversion of Equipment; Startup and Commissioning; Project and Construction Management	2 X Rolls Royce RB211
PCI Energy Services LLC		QA/QC Inspector	
Pittsburgh Corning	Pittsburgh Corning Facility	Cullet Load Out Electrical	
Platte River Power Authority	Rawhide Energy Station	I & E Technician	4 X GE (GTG) Frame 7EA
Platte River Power Authority	Rawhide Energy Station	I & E Technician	4 X GE (GTG) Frame 7EA
Power Barge Corp	Portland Power Barge	Borescope inspection	4 X Pratt & Whitney FT4
Power Barge Corp	Chula Vista and Escondido Power Plants	Facility Inspection Audit	1 X Pratt & Whitney FT4
Power Barge Corp	Portland Power Barge	Operation and Maintenance of 3 Pratt & Whitney FT4(s).	3 X Pratt & Whitney FT4
PSEG	Various Peaking Plants	CMMS Implementation	1 X GE (GTG) Frame 7EA;#3;#GE (GTG) LM6000
PSEG	Essex	Equipment Condition Assessment	1 X GE (GTG) Frame 7FA
PSEG	Various Peaking Plants	Operating Procedure Development	1 X GE (GTG) Frame 7EA
QCI	Duke KGen Power Facility	Hot Gas Path Inspection	3 X GE (GTG) Frame 7EA
QCI	Hines Project	Provided craft labor and tools for Major Steam Turbine Inspection	1 X GE (STG) D Series



Customer	Plant	Services	Equipment
Resolutions Management	B.P. Amoco Bahia de Bizkaia Electricidad, S.L.	Audit of Commissioning and Operations & Maintenance Program	2 X GE (GTG) Frame 9FA DLN2
Resolutions Management	Confidential	Coal Bed Methane (CBM) Project feasibility study.	1 X Various Gas Turbine and Reciprocating Engine Driven Generation Sets
Resolutions Management	Confidential	Combined Cycle Plant Design, Performance Analysis, EPC and O&M Estimates	1 X GE (GTG) Frame 9FA;#21;#GE (GTG) Frame 7FA;#7;#GE (GTG) Frame 6B;#183;#Siemens V94.2A;#182;#Alstom GE 13E2
Resolutions Management	B.P. Amoco Bahia de Bizkaia Electricidad, S.L.	Operations Management, Maintenance Management, and Computerized Maintenance Management System (CMMS) Implementation	2 X GE (GTG) Frame 9FA DLN2
S&W Energy Solutions	Shawaikh Power Plant	Electrical Superintendent Support Services	6 X GE (GTG) LM6000
S&W Energy Solutions	Shawaikh Power Plant	LM6000 Support Services	6 X GE (GTG) LM6000
S&W Energy Solutions	Shawaikh Power Plant	Operations Support	6 X GE (GTG) LM6000
S&W Energy Solutions	Shawaikh Power Plant	Planner/Scheduler	6 X GE (GTG) LM6000
S&W Energy Solutions	Shawaikh Power Plant	QA/QC Superintendent for LM6000 Project	6 X GE (GTG) LM6000
S&W Energy Solutions	Shawaikh Power Plant	Startup Support Services	6 X GE (GTG) LM6000
S&W Energy Solutions		Commissioning Manager Support Services	
S&W Energy Solutions		QA/QC Support Services	
SDGE	Miramar	CMMS Implementation and Operating Procedure Development	1 X GE (GTG) LM6000
Sega, Inc.	Ames Project	Construction Completion and Commissioning Services. Provided Start-up Manager.	1 X GE (GTG) LM2500
Sega, Inc.	Peculiar Simple Cycle Project	Construction Completion and Commissioning Services. Provided Start-up Manager.	3 X Siemens-Westinghouse GTG W501D51
Septagon Construction Company	Alcan Cable	Hand Rail Fabrication	
Septagon Construction Company	Alcan Cable	Hand Rail Fabrication	
Septagon Construction Company	Alcan Cable	Hand Rail Fabrication (140')	
Septagon Construction Company	Alcan Cable	Pipe Bollards Installation	
Septagon Construction Company	St. Paul Lutheran School	Steel Fabrication (Trusses, decking, framing, stairs)	
Septagon Construction Company	St. Paul Lutheran School	Pit Covers Fabrication	
Setar	Tarija, Bolivia	Technical Advisor	
Siemens Fossil Services	Calpine Gilroy Cogen	Craft Labor Support	1 X AEG Kanis Steam Turbine



Customer	Plant	Services	Equipment
Siemens Fossil Services	Siemens Training Facility	Technical Advisor	
Siemens Fossil Services	Comanche Peak	Craft Labor Support	
Siemens Fossil Services	Georgetown # 2 PMDT	Craft Labor Support	1 X M-25
Siemens Fossil Services	St. Francis Power Station	Craft Labor Support	2 X Siemens-Westinghouse GTG V84.3A;#249;#Detroit Diesel T1637K36
Siemens Power Generation, Inc.	Dynegy Danskammer LLC	Boiler Superintendent	1 X 234.4 MW Coal Fired ST
Siemens Power Generation, Inc.	N/A Havana	Owner's Representative	1 X PC Opposed Fire Coal Fired Power Plant
Southeast Texas Industrial Services, Inc.	Al Massaib Project	Lead Electrical Field Engineering to support the installation and commissioning of the gas turbine and balance of plant equipment.	10 X GE (GTG) LM6000
Southeast Texas Industrial Services, Inc.	Al Quds	Mechanical Support Services	1 X GE (GTG) LM6000
Southeast Texas Industrial Services, Inc.	Al Quds	Rotating Equipment Specialist	1 X GE (GTG) LM6000
Southern Company Generation	J.H. Miller Jr. Steam Plant	Outage Scheduler	
Springs Industries, Inc.	Grace Power Plant	Technical Assistance and Outage Management for coal-fired cogeneration facility	1 X Siemens-Westinghouse 9,375 kV Air Cooled Generator
SRP	Agua Fria Generation Station	Technical Advisor	3 X GE (STG)
State of Missouri	Sedalia Armory	Emergency Generator Relocation	
State of Missouri	Sedalia Armory	Hot Start Control Box Installation	
Sterling Energy Operations LLC	Termo Mexicali Project	Instrumentation & Controls	2 X GE (GTG) Frame 7FA
Sterling Energy Operations LLC	Termo Mexicali Project	Operations Support for the commissioning of the gas turbines, steam turbine, and balance of plant equipment	2 X GE (GTG) Frame 7FA
Streamlined Support Systems		QA/QC Manager	
Taft Energy Partners	N/A Chicago	Borescope Inspection	2 X Siemens-Westinghouse GTG W501F
TECO	Beer Column NDE	Beer Column NDE	1 X Ethanol Refinery Plant
TECO	Gila River	Combustion Inspection and Tuning	2 X GE (GTG) Frame 7FA
Tenaska	Tenaska Virginia Partners	Construction, Start-up, & Operations	1 X GE (GTG) Frame 7FA
Tenaska	Lincoln Generating Facility	Controls Scope	1 X Turbine Control System Software
Termoelectrica de Mexicali	Termo Mexicali Project	Installation of a reducing station and new coalescing filters including the relocation of the existing heaters for the inlet gas lines for Units 1 & 2.	2 X GE (GTG) Frame 7FA
TIC- The Industrial Company	Treasure Coast Energy Center	Lead Mechanical Engineer	



Customer	Plant	Services	Equipment
Toromont Energy Services		Construction Superintendent	1 X GE (GTG) LM6000
Toromont Energy Services	Various, Houston	Construction Superintendent	1 X 12M SCFD Methane Gas Compressor Station
Toshiba	Valladolid III	DCS Engineer	2 X GE (GTG) Frame 7FA
Toshiba	Valladolid III	Electrical/Relay Test Engineer	1 X GE (GTG) Frame 7FA
Toshiba	Valladolid III	I&C Turn Over Coordinator	2 X GE (GTG) Frame 7FA
Toshiba	Valladolid III	Lead DCS Engineer	2 X GE (GTG) Frame 7FA
Toshiba	Valladolid III	Lock Out / Tag Out Specialist	2 X GE (GTG) Frame 7FA
Toshiba	Valladolid III	Mechanical Turn Over Specialist	2 X GE (GTG) Frame 7FA
Toshiba	Valladolid III	Start Up Lead Operator	2 X GE (GTG) Frame 7FA
Toshiba America	Altmone Power Plant	Steam Turbine Generator and Controls Training	1 X Toshiba STG
Toshiba America	Candela Power Plant	Steam Turbine Generator and Controls Training	1 X Toshiba STG
Toshiba International Corporation	Calpine Energy- Columbia Facility	Conducted Toshiba On-site Level One Training for Calpine Operators, Maintenance Staff, and Management Personnel.	1 X Toshiba Reheat Steam Turbine;#154;#Toshiba STG;#112;#Toshiba Controls
Toshiba International Corporation	Deer Park Energy Center	Conducted Toshiba on-site Level One Training for Calpine Operators, Maintenance Staff, and Management Personnel.	1 X Toshiba Extraction ST;#154;#Toshiba STG;#112;#Toshiba Controls
Toshiba International Corporation	Florida Power and Light-Marcus Hook Facility	Conducted Toshiba On-site Level One Training for FPL Operators, Maintenance Staff, and Management Personnel.	1 X Toshiba Extraction ST;#154;#Toshiba STG;#112;#Toshiba Controls
Toshiba International Corporation	Progress Energy- Rowan Energy Facility	Conducted Toshiba On-site Level One Training for Progress Energy Operators, Maintenance Staff, and Management Personnel.	1 X Toshiba Extraction ST;#154;#Toshiba STG;#112;#Toshiba Controls
Toshiba International Corporation	Advanced Operator Training (Toshiba Training Center)	Development and execution of all Toshiba Advanced Operator Training for various Toshiba Clients. Provided the only Toshiba Certified Trainer outside of Japan	1 X Toshiba STG
Toshiba International Corporation	Newmont Power Services	Newmont/TS Power Training Services	
Toshiba International Corporation	Edison Facility	Steam Turbine Generator and Controls Training	1 X Toshiba STG
Toshiba International Corporation	Toshiba International Corporation	Technical Training Services	
Transcanada	Becancour Power Plant	Plant Layup	
TTS/Wintara		Controls Technician	1 X Siemens-Westinghouse GTG V64.3A
TTS/Wintara	N/A Iraq	Controls Technician	1 X Siemens-Westinghouse GTG V64.3A



Customer	Plant	Services	Equipment
Turbine Air Systems	Florida Power & Light Martin County Project	Constructability reviews including project budget estimates for various gas turbine inlet chiller projects.	1 X Inlet Cooling System for GE 7FA
Tyson Foods, Inc.	Tyson Foods	Blast Freezer Piping	
Tyson Foods, Inc.	Tyson Foods	Blast Freezer Piping	
Tyson Foods, Inc.	Tyson Foods	Condenser Removal and Reinstallation	
Tyson Foods, Inc.	Tyson Foods	Cut Cap Coils on Blast Cells	
Tyson Foods, Inc.	Tyson Foods	Cut out Valves & Install Caps	
Tyson Foods, Inc.	Tyson Foods	D/A Tank Return Lines Repair	
Tyson Foods, Inc.	Tyson Foods	Debone Scale Relocation	
Tyson Foods, Inc.	Tyson Foods	Discharge Valve Replacement	
Tyson Foods, Inc.	Tyson Foods	Drip Pan Repairs	
Tyson Foods, Inc.	Tyson Foods	Fulton Oil Expansion Tanks	
Tyson Foods, Inc.	Tyson Foods	Install Hot tap on compressor	
Tyson Foods, Inc.	Tyson Foods	Mechanical & Electrical Support Services	
Tyson Foods, Inc.	Tyson Foods	Oven Repairs	
Tyson Foods, Inc.	Tyson Foods	Pack Out Freezer Coil	
Tyson Foods, Inc.	Tyson Foods	Paratherm Flex Line Installation	
Tyson Foods, Inc.	Tyson Foods	Piping Spool Replacement	
Tyson Foods, Inc.	Tyson Foods	Refrigeration Line Leak Repair	
Tyson Foods, Inc.	Tyson Foods	Relocate Drip Pans in Debone	
Tyson Foods, Inc.	Tyson Foods	Replace Condensate Drains	
Tyson Foods, Inc.	Tyson Foods	Spiral Freezer Lines Repair	
Tyson Foods, Inc.	Tyson Foods	Spiral Freezer Lines Repair	
Tyson Foods, Inc.	Tyson Foods	Steam Leak Repair	
Tyson Foods, Inc.	Tyson Foods	Tube chiller Replacement	
Tyson Foods, Inc.	Tyson Foods	Valve & Piping Installation	
Tyson Foods, Inc.	Tyson Foods	Spiral Freezer Repairs	
Tyson Foods, Inc.	Tyson Foods	Removal of inch brake drum on Danly 2	
Tyson Foods, Inc.	Tyson Foods	Piping Spool Replacement	
Tyson Foods, Inc.	Tyson Foods	Blast Freezer # 5 Piping	
Tyson Foods, Inc.	Tyson Foods	Blast Freezer # 4 Piping	
Tyson Foods, Inc.	Tyson Foods	Crane Services for Condenser Removal/Reinstallation	1 X MMH Crane
Tyson Foods, Inc.	Tyson Foods	Bimetal Flanges Installation	
Tyson Foods, Inc.	Tyson Foods	Blast Cell Freezer #5 Repair	



Customer	Plant	Services	Equipment
University of Texas at Austin		Donation of Surplus Equipment	
University Park Energy LLC	University Park Energy	Collector Box Service Bulletins 05M05, 06M06 & 97M03	12 X Pratt & Whitney FT8
University Park Energy LLC	University Park Energy	Implementation of Pratt & Whitney Services Bulletin 05B03	10 X Pratt & Whitney FT8
VeraSun	Aurora	Outage Maintenance Support Services (Welders and Millwrights)	
VeraSun	Aurora	Outage Manager	
VeraSun	VeraSun Fort Dodge	Outage Planner/Scheduler	
Walters Power International	New Albany Facility	Facility Assessment	6 X GE (GTG) Frame 7E
Walters Power International	TAS	Technical Advisor	1 X GE (GTG) LM6000
Waterloo Industries	Sedalia Facility	Hot Tap into Gas Line	
Waterloo Industries	Waterloo Industries, Inc.	Process Air Piping	
Waterloo Industries	Waterloo Industries, Inc.	Process/Breathing Air Piping	
Waterloo Industries	Waterloo Industries, Inc.	Professional Engineer	
Waterloo Industries	Waterloo Industries, Inc.	Hoops Fabrication	
Wheelabrator Air Pollution Controls Inc	Pleasant Power Station	Construction Management Support for wet scrubber installation outage.	1 X 1368 MW Coal Fired Power Plant
Wheelabrator Air Pollution Controls Inc	Pleasant Power Station	Owner's Representative	1 X 1368 MW Coal Fired Power Plant
Wheelabrator Air Pollution Controls Inc	PP&L Montour	Owner's Representative	1 X Tangential OFA LNB Coal Fired Power Plant
Wheelabrator Group	Spirit Aero Systems Facility	Equipment Installation	
Wheelabrator Group	Hayes Lemmerz International Facility	Machinery Electrical Labor Support	
Wheelabrator Group	Hayes Lemmerz International Facility	Machinery Mechanical Labor Support	
Wheelabrator Group	Hayes Lemmerz International Facility	Mechanical Support	
Wheelabrator Group	Hayes Lemmerz International Facility	Millwright Support	
Whiteman Air Force Base	Whiteman Air Force Base	Replacement of Controls at Heat Plant	
Whiteman Air Force Base	Whiteman Air Force Base	Utility Meter Reading/Services Recording	
Wolf Hills Energy LLC	Wolf Hills Peaking Station	9th Stage Stator Shroud Inpection	10 X Pratt & Whitney FT8
Wood Group	The Power Barge	Removal of Power Turbine	3 X Pratt & Whitney FT4
WorleyParsons Group, Inc.	University of Massachusetts	Operations Manager	
WorleyParsons Group, Inc.	Windalco Processing Facility	ST Technical Advisor	
Xcel Energy	Oak Park Heights Facility	I & C Engineer	6 X GE (GTG) Frame 7B



Customer	Plant	Services	Equipment
Xcel Energy	Blue Lake Generating Plant	Operations Procedure Development Services	2 X GE (GTG) Frame 7FA
Xcel Energy	Angus Anson Generating Plant	Operations Procedure Development Services	1 X GE (GTG) Frame 7FA
Xcel Energy	Fort Saint Vrain Combined Cycle Station	Construction Manager	3 X GE (GTG) Frame 7FA